



ASIC
Australian Securities &
Investments Commission

BUSINESS REGISTRATION SERVICE (BRS)

MESSAGE IMPLEMENTATION GUIDE (MIG)

V1.6

Purpose: This document provides guidance for the implementation of web services offered by ASIC

Date: 30 June 2020

Contact: For further information or questions, contact ASIC at webservices@asic.gov.au

DOCUMENT CHANGE CONTROL

Version number	Date of issue	Author(s)	Brief description of change
0.1	22/01/2016	ASIC	Initial Draft
0.2	15/03/2016	ASIC	Amendments to align with schema changes
0.4	15/04/2016	ASIC	Updated
0.5		ASIC	Insert minimum and maximum field lengths
0.6	04/08/2016	ASIC	Refined introductory section
1.0	10/08/2016	ASIC	Final Draft
1.1	16/11/2016	ASIC	Updated from feedback
1.2	28/02/2017	ASIC	Final version released
1.3	26/09/2017	ASIC	Updated for CSF changes
1.4	19/10/2018	ASIC	Updated for CSF changes Amend list of country names
1.5	23/01/2019	ASIC	Add new entity types in getNni, searchNniName and Appendix C
1.6	30/06/2020	ASIC	Remove AusKey Make getTransactionStatus mandatory in 4.3

DISCLAIMER

This specification is current at the latest date shown in the Document Change Control, but it may be amended at any time without prior notice. Only those organisations that have been registered by the Australian Securities and Investments Commission (ASIC) will be notified of changes.

ASIC is not responsible for the quality or merchantability of software developed on the basis of this specification, nor is it responsible for any application packages developed by third parties to access ASIC databases through the BN Web Services interface. ASIC does not support such software in any form.

COPYRIGHT

Copyright© Australian Securities and Investments Commission 2017 with all rights reserved

This document is the property of ASIC. No part of this document may be copied or used in other publications unless ASIC authorship is acknowledged

TABLE OF CONTENTS

1.	INTRODUCTION.....	5
1.1.	Purpose.....	5
1.2.	Audience	5
1.3.	Context.....	5
1.4.	Glossary	6
2.	AUTHENTICATION AND AUTHORISATION	7
3.	SIGNATORY	8
3.1.	Business Name Registration	8
3.2.	Company Registration	13
3.3.	Company name Reservations.....	14
4.	ASIC API INTERACTION	16
4.1.	Web Services	16
4.2.	Prerequisites	16
4.3.	Services Offered.....	17
4.4.	Service Summary.....	17
4.5.	Message Specification	19
5.	PAYING FOR A TRANSACTION.....	21
5.1.	Prerequisites	21
5.2.	Service Summary.....	21
6.	APPLICATION FOR A BUSINESS NAME	22
6.1.	Prerequisites	22
6.2.	Service Summary.....	22
6.3.	Additional Information	22
7.	APPLICATION FOR A COMPANY NAME RESERVATION	23
7.1.	Prerequisites	23
7.2.	Service Summary.....	23
7.3.	Additional Information	23
8.	APPLICATION FOR A COMPANY.....	24
8.1.	Prerequisites	24
8.2.	Service Summary.....	24
8.3.	Additional Information	24
9.	MESSAGE SPECIFICATIONS.....	25
9.1.	Message Specification – queryNameAvailability	25
9.1.1.	Business Overview.....	25
9.1.2.	HTTPS Connections & WSDL.....	25
9.1.3.	queryNameAvailability Request Message	26
9.1.4.	queryNameAvailability Reply Message	29
9.2.	Message Specification - searchNniName	32
9.2.1.	Business Overview.....	32
9.2.2.	HTTPS Connections & Proxy Servers	32
9.2.3.	searchNniName Request Message.....	32
9.2.4.	searchNniName Reply Message	37

- 9.3. Message Specification - getNni 44
 - 9.3.1. Business Overview 44
 - 9.3.2. HTTPS Connections & WSDL 44
 - 9.3.3. getNni Request Message 44
 - 9.3.4. getNni Reply Message 49
- 9.4. Message specification - simpleFeeLookup 55
 - 9.4.1. Business Overview 55
 - 9.4.2. HTTPS Connections & WSDL 55
 - 9.4.3. simpleFeeLookup Request Message 56
 - 9.4.4. simpleFeeLookup Reply Message 59
- 9.5. Message specification - initiatePayment 61
 - 9.5.1. Business Overview 61
 - 9.5.2. HTTPS Connections & WSDL 61
 - 9.5.3. InitiatePayment Request Message 61
 - 9.5.4. initiatePayment Reply Message 83
- 9.6. Message Specification - bnLodgeApplication 90
 - 9.6.1. Business Interaction Overview 90
 - 9.6.2. HTTPS Connections & WSDL 94
 - 9.6.3. bnLodgeApplication Request Message 94
 - 9.6.4. bnLodgeApplication Reply Message 119
- 9.7. Message specification - companyLodgement 122
 - 9.7.1. Business Interaction Overview 122
 - 9.7.2. HTTPS Connections & WSDL 123
 - 9.7.3. companyLodgement Request Message 123
 - 9.7.4. companyLodgement Reply Message 166
- 9.8. Message specification - reservationLodgement 169
 - 9.8.1. Business Overview 169
 - 9.8.2. HTTPS Connections & WSDL 170
 - 9.8.3. reservationLodgement Request Message 170
 - 9.8.4. reservationLodgement Reply Message 184
- 9.9. Message specification - getTransactionStatus 186
 - 9.9.1. Business Overview 186
 - 9.9.2. HTTPS Connections & WSDL 186
 - 9.9.3. getTransactionStatus Request Message 187
 - 9.9.4. getTransactionStatus Reply Message 189
- APPENDIX A – MAPPING ABR ENTITY TYPES TO ASIC ENTITY TYPES 196**
- APPENDIX B - RENEWAL DATE ALIGNMENT 200**
- APPENDIX C – LIST OF VALUES 202**
- APPENDIX D - ALGORITHMS 209**
 - Australian Company Number 209
 - Australian Business Number 210
- APPENDIX E – COMPANY STRUCTURE AND NAMES 211**
 - Company Type, Class and Subclass 211
 - Legal Elements 211
 - Standard share classes 212
 - Name availability objection codes 212

1. INTRODUCTION

1.1. PURPOSE

The purpose of this document is to provide information on the web services offered by ASIC. The document is designed to provide an understanding of the web service operations and associated XML message requests and replies.

1.2. AUDIENCE

The intended audience includes Project Managers, Software Engineers, Software Testers and others involved in the software development process.

Readers should be familiar with the following:

- For information related to [business names](#)
- For information related to [company registrations](#)
- **Web Services Implementation Guide v3.1** – issued in conjunction
- External M2M Error code v3.0 – issued in conjunction

1.3. CONTEXT

ASIC web services require software developers to develop W3C compliant SOAP services to interact with ASIC web services interfaces.

ASIC will deliver a suite of documents and technical products to support software developers with the implementation of the web services required for the interactions with ASIC.

The common technical components and services that are re-used by all services are covered in the **Web Services Implementation Guide v3.1**.

This document details the web service operations available for the transactions between software developers and ASIC. It covers the web service specification for each message/interaction including a business overview of the functionality provided. It describes the structure of the request and the response messages detailing the SOAP Body elements and their business meaning, the business rules and validations applied to the messages.

Note that the web service specification defines what the service is, but not how the service is implemented and therefore is agnostic of the operating system and the software language used.

1.4. GLOSSARY

For definition of the terminology and acronyms used within this document.

Term	Description
ABN	Australian Business Number issued by the Australian Business Register. The ABN is a unique 11 digit identifier.
ACN	Australian Company Number issued by ASIC. The ACN is a 9 digit unique number with a validation algorithm.
ACNC	Australian Charities and Not-for-profit Commission
B2G	Business to Government machine to machine interaction
HTTPS	Hypertext Transfer Protocol Secure. HTTPS is a web protocol that provides encryption and secure connection.
M2M	Machine-to-Machine. In this document, M2M refers to communication between software applications and the ASIC system using web services via internet connection
Reservation	Refers to Australian company name reservation.
SOAP	Simple Object Access Protocol. – SOAP is a standard communication protocol for Web Services.
WSDL	Web Services Description Language
XML	eXtensible Markup Language. XML is a meta-markup language that can be used to define data formats.
XML Schema or Schema	XML Schemas express shared vocabularies and allow machines to carry out rules made by people. They provide a means for defining the structure, content and semantics of XML documents.
Customer	The user of the third party software, generally the person completing the registration.
Transactions	A transaction is created every time payment is initiated successfully, this transaction can host a number of separate lodgements.
Lodgements	A lodgement is each individual registration or reservation sent to ASIC as part of a transaction.
Forms	ASIC terminology to classify a lodgement type.

2. AUTHENTICATION AND AUTHORISATION

Below is the authentication model described in the Web Services Implementation Guide for ASIC.

- a) A username & password credential issued by ASIC

The details on how the authentication and authorisation need to be implemented are outlined in the Web Services Implementation Guide v3.1 (WIG).

The authorisation for the request messages is based on the sender information (i.e. senderType and senderId) that is provided in the SOAP Body – Business Document Header.

3. SIGNATORY

Some of the ASIC request messages contain a 'Signatory' section that includes a few statements indicating that the information contained is 'true and correct'.

To make a declaration, the customer needs to be aware of two things:

- The statements they are making, and
- that they acknowledge the declarations by them agreeing to them.

As a result, in every case where a 'signatory' is required to accompany a transaction, the customer must have displayed to them the declarations described in this section and must take an action to declare they accept.

3.1. BUSINESS NAME REGISTRATION

The software developer is to include the ASIC Eligibility Declaration prior to the final 'declaration' being made by a business name applicant. The applicant must declare that the following statements are true to confirm eligibility to register a business name.

The text of the 'Declaration' and 'Authority' section must display the following:

<p><i>Individual applicant</i></p> <p>Declaration</p> <ul style="list-style-type: none"><input type="checkbox"/> This transaction is submitted for lodgement under, and is compliant with, the terms and conditions of the <u>ASIC Electronic Lodgement Protocol</u>. <input type="checkbox"/> To the best of my knowledge, the information supplied in this transaction is complete and accurate (it is an offence to provide false or misleading information to ASIC).	<p>Authority</p> <p>Please select one.</p> <p>I declare that:</p> <ul style="list-style-type: none"><input type="checkbox"/> I am the applicant (the proposed business name holder) <input type="checkbox"/> I am lodging this application on behalf of the applicant (the proposed business name holder) and am authorised to:<ul style="list-style-type: none">• submit this application for lodgement on behalf of the applicant under the terms and conditions of the ASIC Electronic Lodgement Protocol; and • make each of the above declarations on behalf of the applicant after making all due and proper enquiries. <p>ASIC may contact the applicant or the lodging party (if any) if there are any questions regarding this application for registration of a business name</p>
--	--

<p>Eligibility</p>	<p>The applicant must declare that the following statements are true to confirm eligibility to register a business name.</p> <p>If you are not the applicant you must be authorised by the applicant to make either of these declarations on behalf of the applicant:</p> <p>Declaration by applicant of eligibility to hold a business name:</p> <ul style="list-style-type: none">• I am not disqualified from managing corporations under section 206B(1) of the Corporations Act 2001; and <input data-bbox="874 719 911 757" type="checkbox"/> <ul style="list-style-type: none">• Within the last 5 years I have not been:<ul style="list-style-type: none">• convicted of, or• released from prison after being convicted of, and serving a term of imprisonment for, any of the criminal offences referred to in section 32(1) (c) or (d) of the Business Names Registration Act 2011
---------------------------	--

<p><i>Other than individual applicant</i></p> <p>Declaration</p> <ul style="list-style-type: none"><input type="checkbox"/> This transaction is submitted under, and is compliant with, the terms and conditions of the <u>ASIC Electronic Lodgement Protocol</u><input type="checkbox"/> To the best of my knowledge, the information supplied in this transaction is complete and accurate (it is an offence to provide false or misleading information to ASIC).	<p>Authority</p> <p>I declare that:</p> <ul style="list-style-type: none"><input type="checkbox"/> I am lodging this application on behalf of the applicant (the proposed business name holder) and am authorised to:<ul style="list-style-type: none">• submit this application for lodgement on behalf of the applicant under the terms and conditions of the ASIC Electronic Lodgement Protocol; and• make each of the above declarations on behalf of the applicant after making all due and proper enquiries. <p>ASIC may contact the applicant or the lodging party (if any) if there are any questions regarding this application for registration of a business name.</p>
---	---

<p>Eligibility</p>	<p>The applicant must declare that the following statements are true to confirm eligibility to register a business name.</p> <p>If you are not the applicant you must be authorised by the applicant to make either of these declarations on behalf of the applicant:</p> <p>Declaration by applicant of eligibility to hold a business name:</p> <ul style="list-style-type: none"> • I am not disqualified from managing corporations under section 206B(1) of the Corporations Act 2001; and <p><input type="checkbox"/></p> <ul style="list-style-type: none"> • Within the last 5 years I have not been: <ul style="list-style-type: none"> • convicted of, or • released from prison after being convicted of, and serving a term of imprisonment for, any of the criminal offences referred to in section 32(1) (c) or (d) of the Business Names Registration Act 2011
---------------------------	--

The sender must sign by actively confirming that they are aware of their obligations by using a "tick box", "radio button", a "submit button" or any similar method that the software developer chooses to implement within their software product.

3.1.1 Privacy statement

Software preparing lodgements to update ASIC's register must display the following privacy statement to users:

"Privacy The information provided to ASIC in this form may include personal information. Please refer to our privacy policy (www.asic.gov.au/privacy) for more information about how we handle your personal information, your rights to seek access to and correct personal information, and to complain about breaches of privacy."

3.2. COMPANY REGISTRATION

<p>Consents and agreements</p> <p>Software preparing company registration applications must include the ASIC company registration declaration to the user. The applicant must declare that the following statements are true to confirm eligibility to register a company. If the statement is untrue, the application will not be accepted.</p>	<p>The text of this declaration must display the following:</p> <p><i>"I apply for the registration of a company on the basis of the information in this form and any attachments. I have the necessary written consents and agreements referred to in this application concerning the members and officeholders and I shall give the consents and agreements to the company after the company becomes registered. The information provided in this application and in any annexures is true and correct at the time of signing."</i></p>
<p>Special Purpose Companies</p> <p>Software preparing company registration applications where the company nominates that they are a special purpose company must have users assent to the following declaration.</p>	<p>The text of this declaration must display the following:</p> <p><i>"I declare that this company is a special purpose company as defined under Regulation 3 of the Corporations (Fees) Regulations 2003."</i></p>
<p>Identical Business Names</p> <p>Software preparing company registration where the proposed company name is identical to a previously registered business name must have users make the following declaration.</p>	<p>The text of this declaration must display the following:</p> <p><i>"I declare that I hold, or am registering the company for the holder(s) of the identical business name(s), the registration details of which are listed below."</i></p>

<p>Privacy statement</p> <p>Software preparing lodgements to update ASIC's register must display the following privacy statement to users.</p>	<p>The text of this statement must display the following:</p> <p><i>"Privacy The information provided to ASIC in this form may include personal information. Please refer to our privacy policy (www.asic.gov.au/privacy) for more information about how we handle your personal information, your rights to seek access to and correct personal information, and to complain about breaches of privacy."</i></p>
<p>Crowd Sourced Funding</p> <p>Software preparing company registration where the company nominates that they intend to raise crowd sourced funds must have users assent to the following declaration</p>	<p>The text of this statement must display the following:</p> <p><i>"The company intends to make a crowd-sourced funding offer after registration and is eligible for limited governance requirements under section 738Z1 of the Corporations Act 2001 on registration."</i></p>

3.3. COMPANY NAME RESERVATIONS

<p>Identical Business Names</p> <p>Software preparing company name reservation application where the proposed company name is identical to a previously registered business name must have users make the following declaration.</p>	<p>The text of this declaration must display the following:</p> <p><i>"I declare that I hold, or am registering the company for the holder(s) of the identical business name(s), the registration details of which are listed below."</i></p>
<p>Privacy statement</p> <p>Software preparing lodgements to update ASIC's register must display the following privacy statement to users.</p>	<p>The text of this statement must display the following:</p> <p><i>"Privacy The information provided to ASIC in this form may include personal information. Please refer to our privacy policy (www.asic.gov.au/privacy) for more information about how we handle your personal information, your rights to seek access to and correct personal information,</i></p>

	<i>and to complain about breaches of privacy."</i>
--	--

4. ASIC API INTERACTION

The services available may only require a single web service or a sequence of multiple web services to be executed.

4.1. WEB SERVICES

ASIC will process request one at a time; a separate request must be made for each lodgement.

The services covered in this document must be implemented according with the common rules and specifications documented in the **Web Services Implementation Guide v3.1**

4.2. PREREQUISITES

- The customer must register with ASIC to use our services
- username & password authentication must be obtained from ASIC

4.3. SERVICES OFFERED

ASIC exposes the following web services:

SERVICE	DESCRIPTION	REPEATABLE	COMPANY RESERVATION	COMPANY REGISTRATION	BN REGISTRATION
queryNameAvailability	To query the availability of a proposed name.	Yes	Optional	Optional	Optional
searchNniName	Searches ASIC Registers by name/type/status.	Yes	Optional	Optional	Optional
getNni	Returns publically available company data	Yes	Optional	Optional	Optional
simpleFeeLookup	Returns the Fees for the nominated registration	Yes	Optional	Optional	Optional
initiatePayment	Used to make payment for a registration	No	Mandatory	Mandatory	Mandatory
bnLodgeApplication	Used for a business name registration	No	Not used	Not used	Mandatory
companyLodgement	Used for a company registration	No	Not used	Mandatory	Not used
reservationLodgement	Used to reserve or extend the reservation for a company name	No	Mandatory	Not used	Not used
getTransactionStatus	Returns the status of the transaction with ASIC	Yes	Mandatory	Mandatory	Mandatory

4.4. SERVICE SUMMARY

The ASIC web services flow below highlights the order in which the services can be executed. The flow chart highlights the messages that would typically be used in the following 4 stages:

Pre-submission - gathering all the information required to lodge with ASIC

Making payment - paying for all the registrations that will be sent to ASIC under this transaction

Submission - sending each registration for the created transaction to ASIC

Outcome - retrieving the outcome of the transaction from ASIC, including any supporting documentation

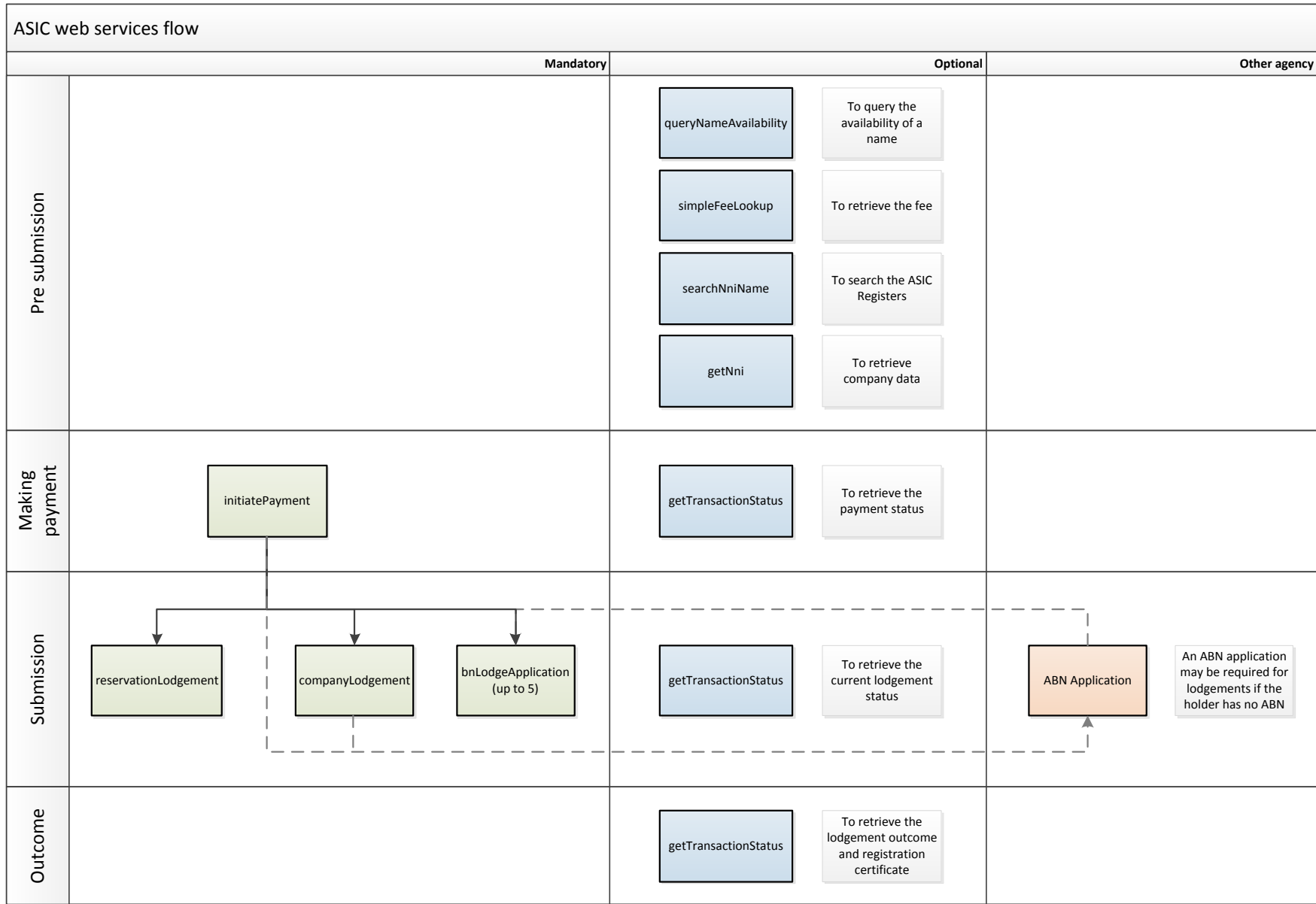



4.5. MESSAGE SPECIFICATION

The message specification defines the business rules and the schema validations for each service. This is supplemented by the information contained in the WSDL files.

The message specification section of this document also includes a diagrammatic representation of each schema or complex type. The message content tables for the request and reply messages are also documented.

General characteristics for schema representations:

- **Optional elements** - indicated by a broken line
- **Mandatory elements** - indicated by a continuous line and must be provided or otherwise the request will fail schema validation (returns a SOAP fault)
- **Mandatory/Optional** - are enforced in a hierarchical structure from root to leaf node. Thus for example if an optional complex element is transmitted, then any mandatory elements within the element must be transmitted.
- **complexType elements** - to simplify the message layout documentation. They consist of set of elements, which have an inherent structure and are combined to form a complex type. An example is an address.
- **Repetition** - elements may be specified to occur multiple times i.e. to repeat. A repeat count in the schema shows the maximum number of occurrences of repeating segments or Complex contents.
- **Mandatory/Conditional/Unused** - elements may be designated to be mandatory or conditional in the definition of a message. Elements may also be designated as being unused when the data they represent is not needed in the particular message type being defined
-  - this indicates that one selection must be made from the available choices
-  - this indicates a sequence of elements that must be provided in accordance with their optionality and the business rules

The Message Content Table Explained:

Each message specification (request and reply) contains a table structure that is used to define the business definition, the structure and business rules of the elements contained within the XML schema. The message content is defined in the table using the following columns:

Sequence Number: This is a sequential number used to indicate the expected order of the data elements within the XML instance document. Elements within a complex content are allocated a multilevel number to indicate the expected structure and order of the elements contained within the Complex content. If there are nested Complex contents then the sequence number goes to next numbering level.

XML Element: This is the name of the data element to be reported.

Type: This is the type of the element and can be a standard XML type or an ASIC defined type.

Description: This is the description of the data element using business terms.

Business Rules/Instructions: This column describes all the rules applicable to the data element. Rules would include information such as optionality, explicit conditions or the expected values and their meaning.

5. PAYING FOR A TRANSACTION

The initiatePayment message is used to make a credit card payment for intended registrations.

The message starts a payment initiation transaction with ASIC. It allows the client to notify ASIC of their intention to lodge and pay for one or more registration applications. The allowed combinations are:

1 company registration and/or up to 5 business name registrations.

or

1 company name reservation or reservation extension

The message will validate the request details, confirm the name availability of each registration, assess any required fees, and return a payment URL for the applicant to make a credit card payment.

5.1. PREREQUISITES

In addition to the conditions listed in section 4.2 Prerequisites:

- The business name(s) and/or company name and details must be known.
- ABN/holder details are required to be the same for each transaction. When a transaction contains multiple registrations, they must all be held by the same entity. For example if a transaction contains a company and multiple business names, the business names must be held by the company.

5.2. SERVICE SUMMARY

Details of the service are provided in section 9 of this document.

Please refer to section 4.4 for the overview on when the initiatePayment message would be used.

6. APPLICATION FOR A BUSINESS NAME

This bnLodgeApplication service is used to register business names with ASIC. Once approved the customer will receive an email that contains the Record of Registration and their ASIC Key.

6.1. PREREQUISITES

In addition to the conditions listed in section 4.2 Prerequisites:

- Payment has been successful
- The holder of the proposed business name has a current ABN or has applied for an ABN and has a valid ABN Reference Number. There are exceptions for Christmas and Cocos Island businesses.
- ABN details will be validated with the ABR in real-time to ensure the ABN/ABN Reference is valid, current and that of the corresponding entity provided.

6.2. SERVICE SUMMARY

The interactions required for the completion of a business name registration consist of the services described in 4.3 Services offered.

Details of the business name service are provided in section 9 of this document.

Please refer to section 4.4 for the overview on when the bnLodgeApplication message would be used.

6.3. ADDITIONAL INFORMATION

If ASIC requires any attachments as supporting evidence for the business name application, it will need to be sent to BN.Names.Determination@asic.gov.au with the proposed name as the subject.

7. APPLICATION FOR A COMPANY NAME RESERVATION

The reservationLodgement service is used to reserve a company name or extend the reservation of an existing reserved company name. The customer will receive an email with the reservation outcome on completion.

7.1. PREREQUISITES

Refer to section 4.2 Prerequisites:

- Payment has been successful
- For a reservation extension, a current reservation must exist with ASIC.

7.2. SERVICE SUMMARY

The interactions required for the completion of a company name reservation or extension consist of the services described in 4.3 Services offered.

Details of the company name reservation service are provided in section 9 of this document.

Please refer to section 4.4 for the overview on when the reservationLodgement message would be used.

7.3. ADDITIONAL INFORMATION

If ASIC requires any attachments as supporting evidence for the application, it will need to be sent to ecr.support@asic.gov.au with the name as the subject.

8. APPLICATION FOR A COMPANY

The companyLodgement service is used to register a company. The customer will receive an email with the registration outcome on completion. When the company is registered ASIC will send the corporate key to the registered office address.

8.1. PREREQUISITES

In addition to the conditions listed in section 4.2 Prerequisites:

- Payment has been successful

8.2. SERVICE SUMMARY

The interactions required for the completion of a company registration consist of the services described in 4.3 Services offered.

Details of the company registration service are provided in section 9 of this document.

Please refer to section 4.4 for the overview on when the companyLodgement message would be used.

8.3. ADDITIONAL INFORMATION

If ASIC requires any attachments as supporting evidence for the application, it will need to be sent to ecr.support@asic.gov.au with the name as the subject.

9. MESSAGE SPECIFICATIONS

9.1. MESSAGE SPECIFICATION – queryNameAvailability

9.1.1. Business Overview

This web service allows users to query and check ASIC's registers (i.e. companies or business names) for the availability of a proposed name, including the availability of a cancelled business name that is intended for transfer (to new registration).

For companies, the proposed name is tested against the following criteria:

- Check for identical and near identical names
- Check for invalid symbols
- Check for restricted words including known words such as "ASX", "BANK", etc
- Check for unknown words

For business names, name availability criteria are documented Business Names Registration Act 2011, Business Names Registration (Availability of Names) Determination 2015. In addition to the criteria listed above for companies, additional criteria include at a conceptual level:

- Word group order
- Phonetic (sounds-like) similarity

Below is the high level definition of the queryNameAvailability service.

Request includes:

- the proposed name
- existing holder details which allows similar results to be ignored if the names are already held by that entity

Reply includes:

- The result provides information regarding the availability of the name based on the result of the names determination function. For example: name is available or name not available or name must be referred to manual determination (i.e. a manual process of assessing the particular instance) or that a name has been previously cancelled and it is available to be transferred to a new holder
- Objections that provide additional information regarding the reason(s) why an application for this name would result in rejection or referral.

9.1.2. HTTPS Connections & WSDL

The requestor's code must establish a HTTPS connection to the appropriate endpoint using the standard port 443.

Environment	WSDL
Production	https://www.gateway.asic.gov.au/gateway/ExternalQueryNameAvailabilityPortV2?WSDL
Test	https://www.gateway.uat.asic.gov.au/gateway/ExternalQueryNameAvailabilityPortV2?WSDL

9.1.3. queryNameAvailability Request Message

Business Document Header

The WIG provides the specification of the Business Document Header. The following table specifies the message specific data element values or any variations to the WIG.

Element Name	Instructions / Rules	Error code
MessageType	Mandatory, value must be "queryNameAvailability"	00002
MessageVersion	Mandatory, value must be 2	00004
senderType	Mandatory, value must be "REGA"	00005
senderId	The identifier assigned by ASIC on registration	00005

Business Document Body

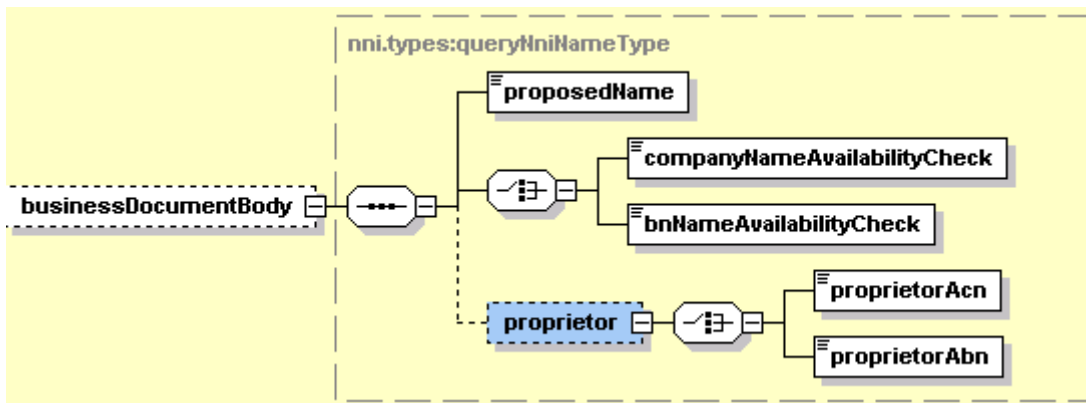

Message Content Table

Seq.No	XML Element	Type	Description	Business Rules/Instructions
1	proposedName	types:nniNameType	The proposed name.	<p>1. Must use UPPERCASE and it can contain spaces.</p> <p>2. Valid characters are:</p> <ul style="list-style-type: none"> ✓ letters, that is alphabetic characters A to Z ✓ numbers, that is numeric characters 1 to 9 and 0 ✓ standard use punctuation marks such as . , ? ! () { } : ; ' " " ✓ the symbols -) _ \ / which are treated as punctuation ✓ the symbols @ # \$ % * = and the ampersand '&'
2	companyNameAvailabilityCheck	types:trueType	Indicator to perform names determination query against Company rules	Setting a value of "true" performs a check to determine the availability of the name as a company name
3	bnNameAvailabilityCheck	types:trueType	Indicator to perform names determination query against Business names rules	<p>Setting a value of "true" performs a check to determine the availability of the name for a business names</p> <p>Note that for the purpose of lodging the application for business names, this value must be 'true'.</p>
4	Proprietor	Complex content	Contains one identifier (i.e. ACN or ABN) for an entity that intends to apply for a new business name. When one identifier is provided than the same holder exemption is applied so the holder can have a name that is similar or nearly identical with the company/entity name	

Seq.No	XML Element	Type	Description	Business Rules/Instructions
4.1	proprietorAcn	types:nniNumberType	ACN for the company that intends to apply for a new business name and whose name may be similar or nearly identical to the proposedName	<ol style="list-style-type: none"> 1. The ACN provided must exist in ASIC register 2. The ACN provided must belong to a registered company 3. Specific to Business Name Availability query only
4.2	proprietorAbn	types:abnType	ABN for the holder of new business names whose other names may be similar or nearly identical to the proposedName.	<ol style="list-style-type: none"> 1. The ABN provided must exist in ABR register 2. The ABN provided must belong to a registered business 3. Specific to Business Name Availability query only

9.1.4. queryNameAvailability Reply Message Business Document Body

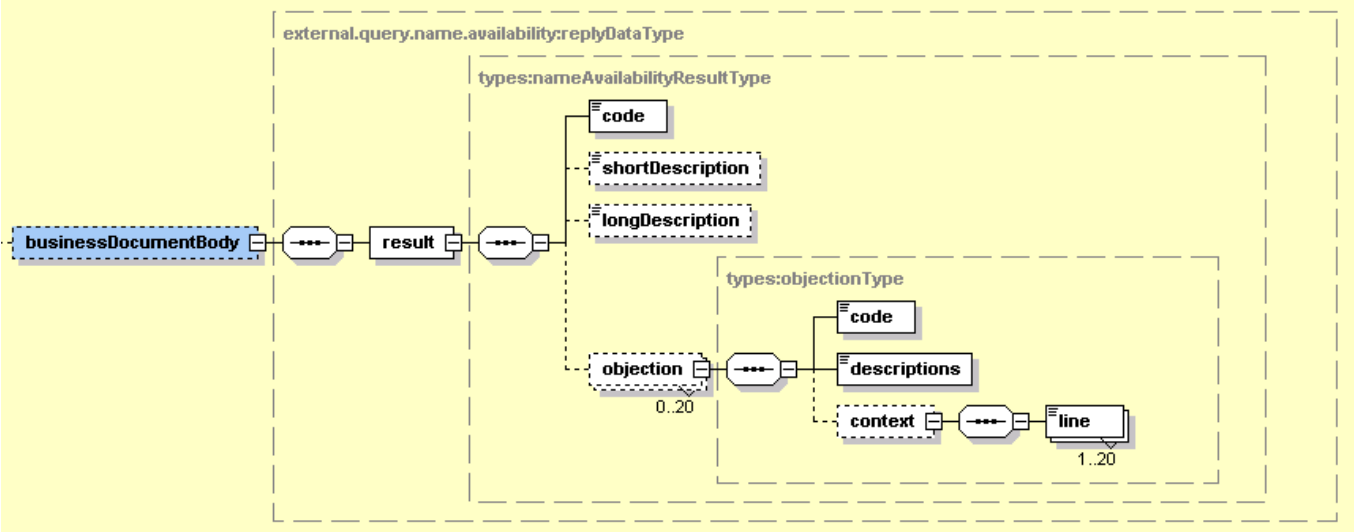

Message Content Table

Seq No	XML Element	Type	Description
1	Result	complexType	Contains the result of the name determination
1.1	code	xs:string	Will return one of the following valid values : Available – the name is available to be used as a business name (or company name) – depending on which Name Availability check was requested Unavailable – the name can't be used and the user should propose another name SubjectToNamesDetermination – the name is referred to ASIC staff for manual assessment UnderTransfer – the name has been previously cancelled with the intention to transfer to another business name holder (status valid for business names only) Identical and near identical– meaning the name is conflicting with another name (under the applicable legislation) and it will be rejected
1.2	shortDescription	xs:string	A short text description associated with the result code returned that should be displayed to the users in order to help them understand the result of the query (if the name availability outcome is being presented in a UI).
1.3	longDescription	xs:string	Long text description associated with the result code returned that should be displayed to the users in order to help them understand the result of the query (if the name availability outcome is being presented in a UI).
1.4	Objections	complexType	Indicates the reason for a rejection or for a referral to manual determination using an ASIC code and a user description. Note that: 1. No objections are returned in the case where result code is 'Available' 2. No objections are returned if a Company Name availability check is requested
1.4.1	Code	xs:string	

Seq No	XML Element	Type	Description
1.4.2	Descriptions	xs:string	<p>The code used by ASIC for the objections. It is returned only if the name is unavailable or is referred to manual processing. Refer to appendix E for some examples of likely name availability objection codes.</p> <p>Please note that is best to develop a generic process to display the code and description as opposed to hard coding these. ASIC may in time choose to tweak or embellish upon the objection descriptions.</p>
1.4.3	Context	complexType	Additional information returned when the name is identical or near identical to another existing name.
1.4.3.1	Line	xs:string	Contains the ASIC internal identifier and the business name or Australian Company Number and the company name that resulted in the exact match (i.e. the existing registered name).

9.2. MESSAGE SPECIFICATION - searchNniName

9.2.1. Business Overview

This web service may be used for searching ASIC registers for registered businesses or companies with names similar with the proposed business name. It allows the searching of the National Name Index using the entity name as search criteria and optionally the type or status of the entity. The request must specify if the search should look for an exact match or for all matching entries.

Request includes:

- entity name and optionally its status and/or type
- type and scope of the search
- a maximum number of results

Reply includes:

- list of all entities (maximum of 99) that match the specified criteria and their details such as identifier, name, type, status, dates for registration / deregistration / renewal / review
- a flag to indicate whether the entity is registered with the Australian Charities and Not-for-Profits Commission (ACNC). It is not mandatory for this information to be displayed in the result that is presented to the user.

If there is no match then the response will indicate this with an error message. If more than 100 entries are found at the exact match level or if no exact match entries are found and more than 100 entries are found at the primary key match levels then the reply will contain an error message which will indicate this.

9.2.2. HTTPS Connections & Proxy Servers

The requestor's code must establish a HTTPS connection to the appropriate endpoint using the standard port 443.

Environment	WSDL
Production	https://www.gateway.asic.gov.au/gateway/ExternalSearchNniNamePortV3?WSDL
Test	https://www.gateway.uat.asic.gov.au/gateway/ExternalSearchNniNamePortV3?WSDL

9.2.3. searchNniName Request Message

Business Document Header

The WIG provides the specification of the Business Document Header. The following table specifies the message specific data element values or any variations to the WIG.

Element Name	Instructions / Rules	Error code
MessageType	Mandatory, value must be "searchNniName"	00002
MessageVersion	Mandatory, value must be 3	00004

Element Name	Instructions / Rules	Error code
senderType	Mandatory, value must be "REGA"	00005
senderId	The identifier assigned by ASIC on registration	00005

Business Document Body

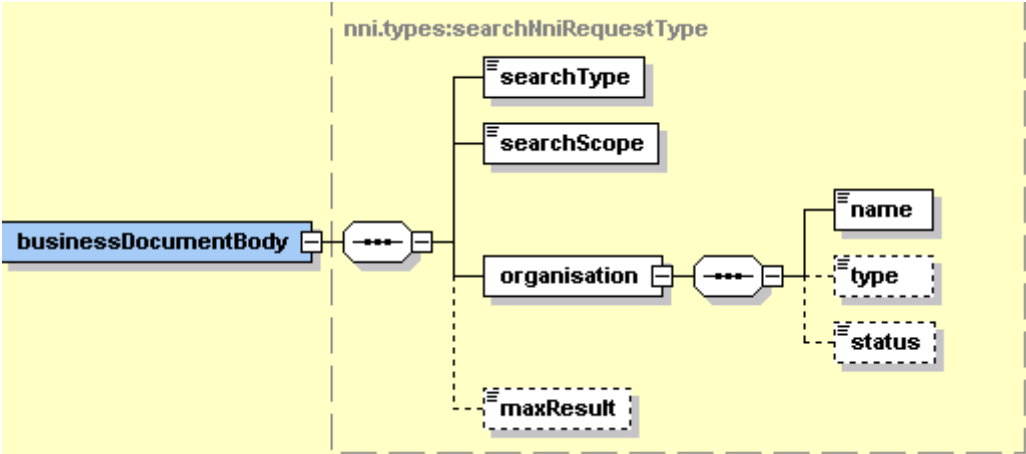

Message Content Table

Sequence No	XML Element	Type	Description	Business Rules/Instructions
1	searchType	xs:string	The type of search to be performed	<p>The valid choices are:</p> <ul style="list-style-type: none"> E – for an Exact (100%) match only S – for the Standard search where all matching entries will be returned <p>Note: In the context of applying for a business name, we suggest to use searchType = S</p>
2	searchScope	xs:string	The scope of the search	<p>Valid scope code:</p> <ul style="list-style-type: none"> 1 – to search for names valid for purchase of extract 2 – to search for names (including former names) of currently registered organisations and reserved names considered for names determination 3 – same as for 2 but including deregistered organisations A – to search for all entities B – to search for Business Names (BUSN) and State Registered Businesses (i.e. ASSN, COOP, LTDP) C – to search for Registered & Deregistered companies, Trusts and NRET's E – to search for Registered companies and NRET's G – to search for Registered companies, Name Reservations, Trusts, NRET's, Business Names and State Registered Businesses (i.e. ASSN, COOP, LTDP) H – to search for Registered & Deregistered companies, Name Reservations, Trusts, NRET's, Business Names (BUSN) and State Registered Names (i.e. ASSN, COOP, LTDP) I – to search for NONC's, Registered companies, Trusts and NRET's J - to search for Registered companies and Name Reservations L – to search for NONC's and Business Names (BUSN) M – to search for NONC's and Name Reservations N – to search for NONC's (Non Company Names) O – to search for NONC's and Registered companies T – to search for Trusts & Registered Schemes R – to search for Registered companies S – to search for Registered companies, Name Reservations, NRET's, Business Names (BUSN) and State Registered Businesses (i.e. ASSN, COOP, LTDP)

Sequence No	XML Element	Type	Description	Business Rules/Instructions
				<p>P – to search for Current Name Reservations X – to search for Registered companies, Name Reservations and Business Names (BUSN) Note: In the context of applying for a business name, we suggest to use searchScope = A</p>
3	Organisation	complexType	Contains the name and optionally the type and status for the entity to be searched for	<ol style="list-style-type: none"> 1. The entity with the name & type & status specified must exist in NNI 2. If there are more than 100 names matching then more information must be provided
3.1	Name	types:nniNameType	Name of the entity to be searched for in the National Name Index	The name must exist in ASIC records
3.2	Type	nni.types:nniTypeCodeType	The type of entity that may be used to narrow down the search results.	<p>Valid values are: APTY - Australian Proprietary Company APUB - Australian Public Company ARPA - Australian Passport Fund ARPF - Foreign Passport Fund ASSN - Association BUSN - Business Name CHAR - Charity COMP - Community Purpose COOP - Co-Operative Society FNOS - Foreign Company (Overseas) LTDP - Limited Partnership MISM - Managed Investment Scheme NONC - Non-Company NRET - Non-Registered Entity (Nret) RACN - Registered Australian Body REBD - Religious Body RSVN - Name Reservation SOLS - Solicitor Corporation TRST - Trust</p> <p>If no value is specified, the message will return all types</p>

Sequence No	XML Element	Type	Description	Business Rules/Instructions
3.3	Status	nni.types:searchStatusType	The status of the entity that may be used to narrow down the search results.	Valid values for business names are: REGD meaning registered business names DRGD meaning cancelled business names PEND – meaning pending business names If no value is specified, the message will return all statuses
4	maxResult	xs:positiveInteger	Maximum number of entities to be returned	The number must be less than 100

9.2.4. searchNniName Reply Message Business Document Body

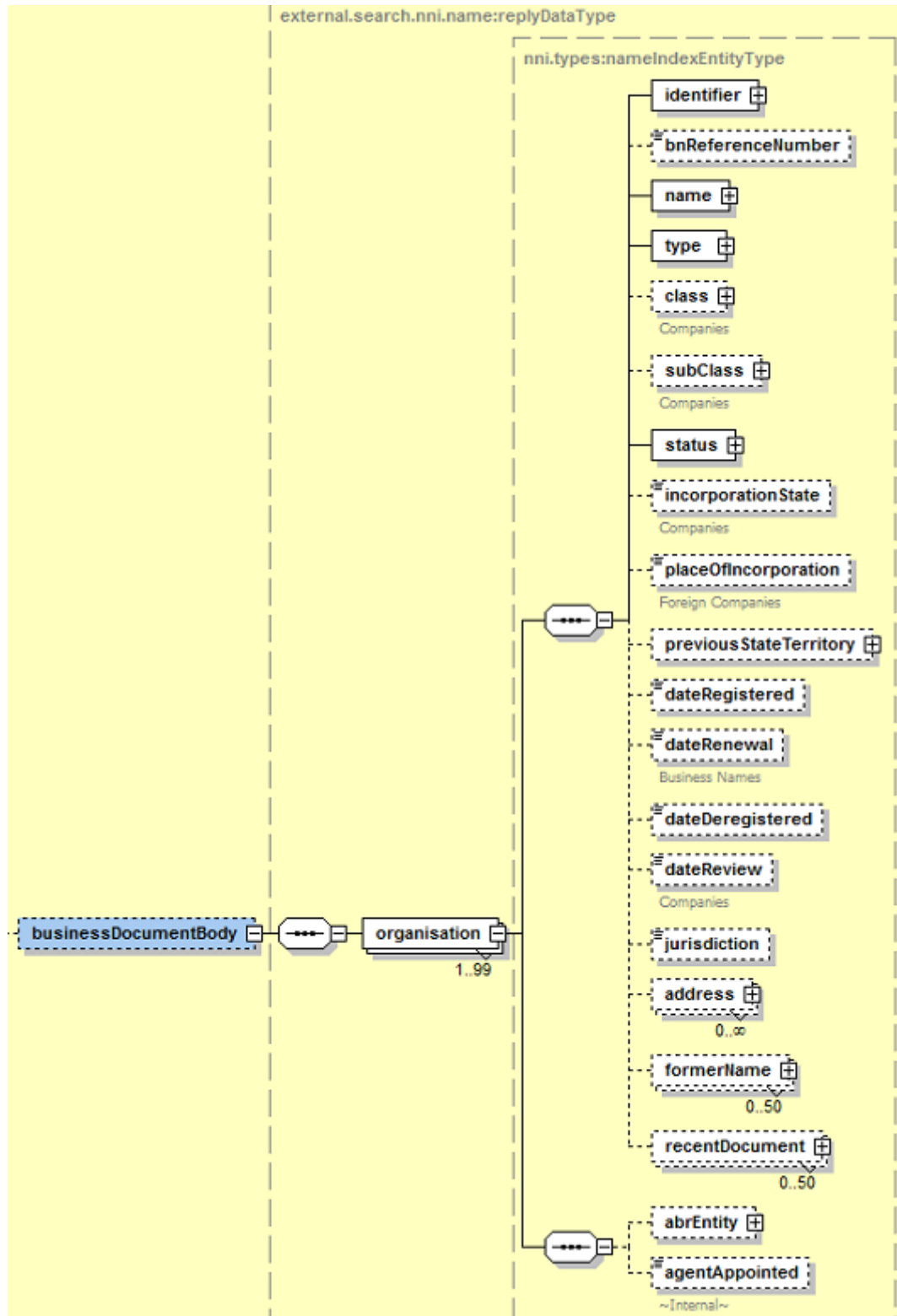

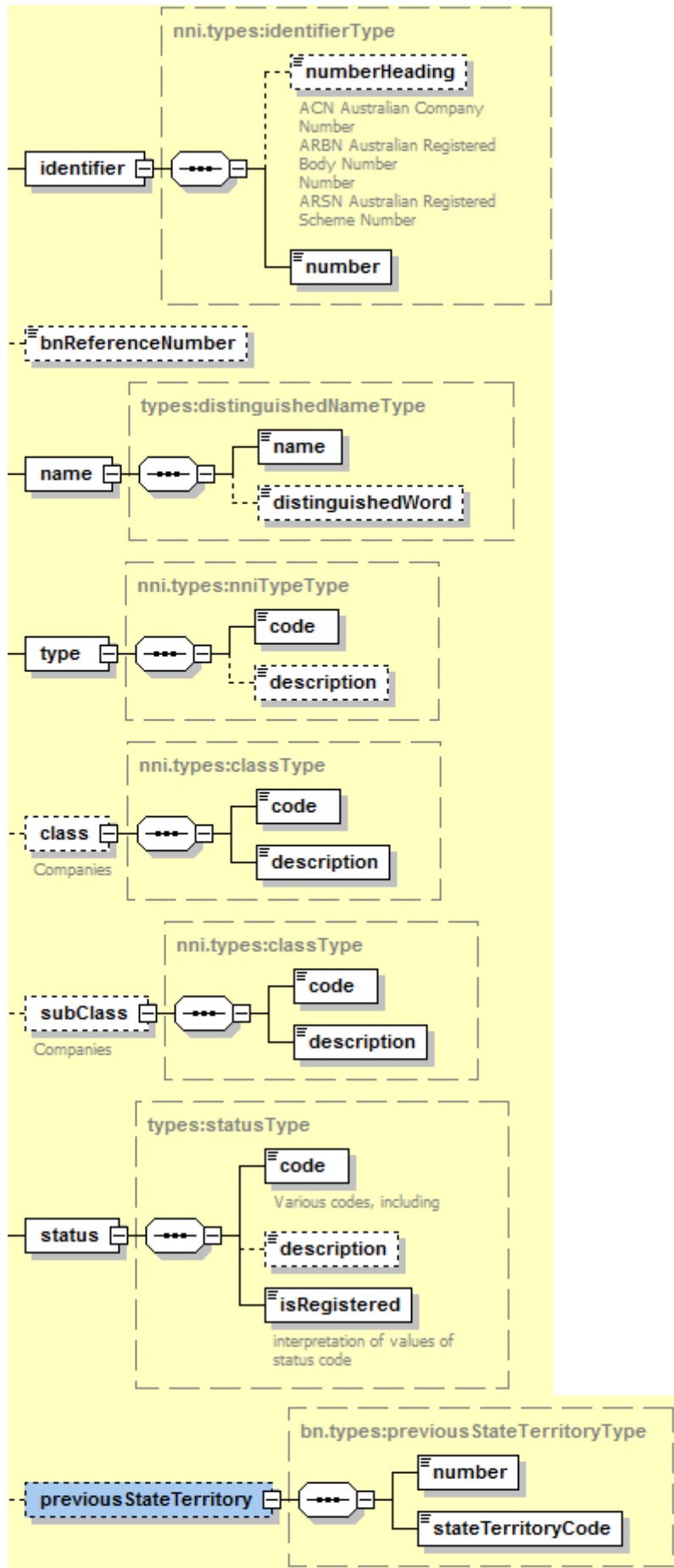

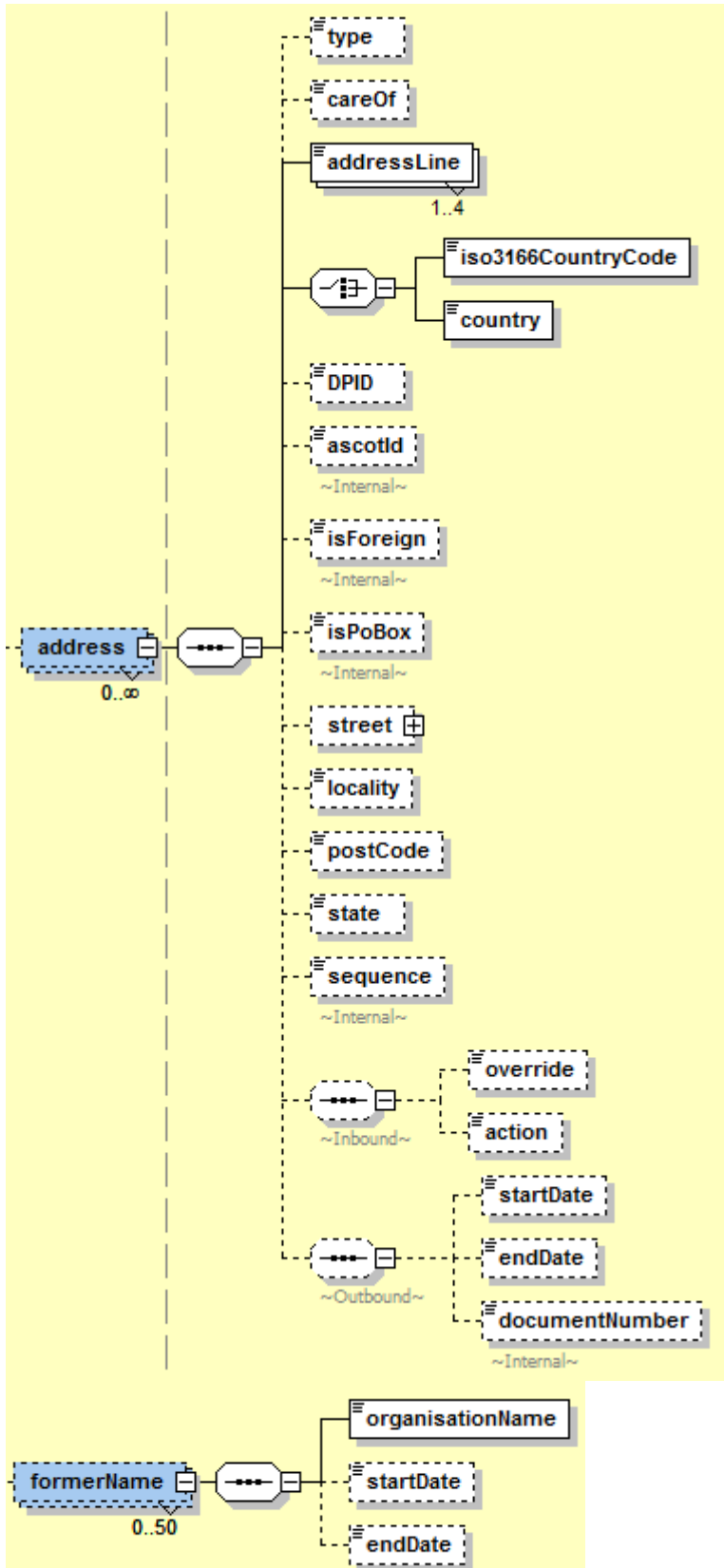

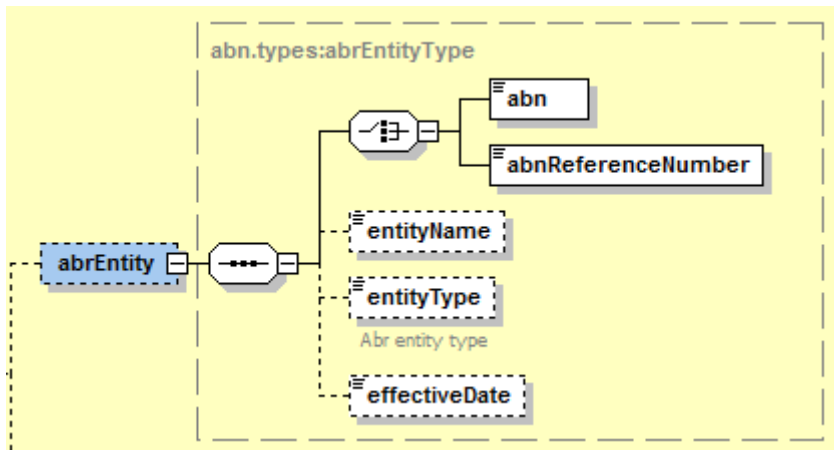
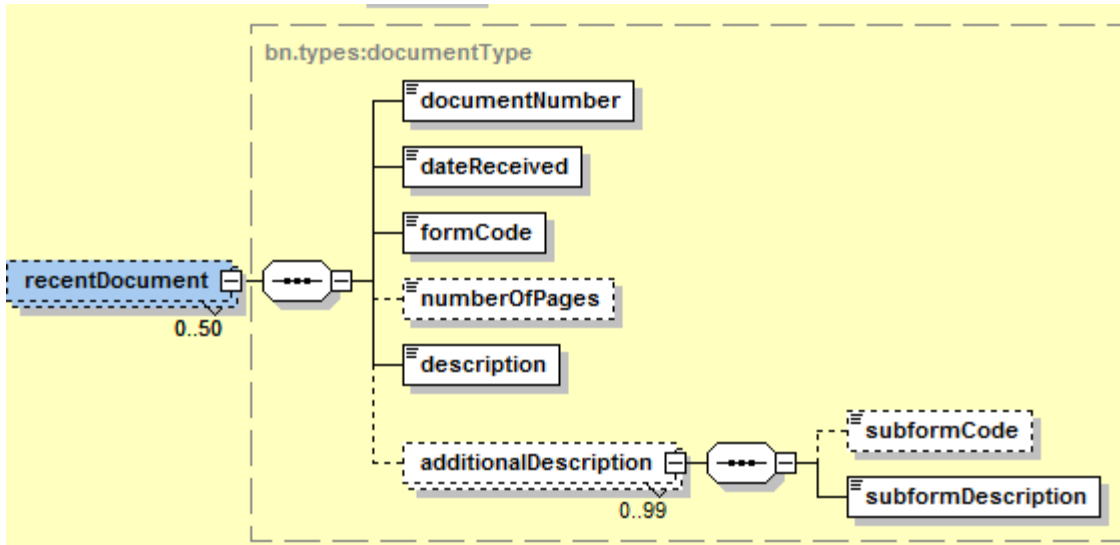

Message Content Table

Seq. No	XML Element	Type	Description
1	organisation	Complex Content	List of organisations that match the criteria specified in the request
1.1	identifier	Complex content	Contains the type and the value for one of the ASIC identifiers such as ACN or ARBN or ARSN
1.1.1	numberHeading	nni.types:numberHeadingType	Type of identifier such as: ACN – meaning Australian Company Number ARBN - meaning Australian Registered Body Number ARSN - meaning Australian Registered Scheme Number Number – used for all other types of identifiers not mentioned above NOTES: <ul style="list-style-type: none"> • ACN, ARBN and ARSN are public identifiers and should be displayed on the user interface; • 'Number' indicates that the identifier is not public and must not be displayed on UI (to be used for m2m interactions only)
1.1.2	number	types:nniNumberType	The value of the ASIC unique identifier
1.2	bnReferenceNumber	types:bnReferenceNumberType	Not relevant for this message
1.3	name	types:distinguishedNameType	Contains the organisation name in ASIC registry
1.3.1	name	types:nniNameType	Name of the entity
1.3.2	distinguishedWord	types:distinguishedWordType	The distinguished word that might be used for distinguishing identical business names registered by States & Territories Agencies.
1.4	type	Complex content	Contains the code and a description for the type of organisation
1.4.1	code	nni.type:nniTypeCodeType	Four letter code associated with the type of entity, with the following available combinations of code -description: APTY - Australian Proprietary Company APUB - Australian Public Company ARPA - Australian Passport Fund ARPF - Foreign Passport Fund ASSN - Association BUSN - Business Name CHAR - Charity COMP - Community Purpose COOP - Co-Operative Society FNOS - Foreign Company (Overseas) LTDP - Limited Partnership MISM - Managed Investment Scheme NONC - Non-Company NRET - Non-Registered Entity (Nret) RACN - Registered Australian Body REBD - Religious Body RSVN - Name Reservation SOLS - Solicitor Corporation

Seq. No	XML Element	Type	Description
			TRST - Trust
1.4.2	description	xs:string	The description of the type of organisations as above. <ul style="list-style-type: none"> ▪ Australian Proprietary Company ▪ Australian Public Company ▪ Australian Passport Fund ▪ Foreign Passport Fund ▪ Association ▪ Business Name ▪ Charity ▪ Community Purpose ▪ Co-Operative Society ▪ Foreign Company (Overseas) ▪ Limited Partnership ▪ Managed Investment Scheme ▪ Non-Company ▪ Non-Registered Entity (Nret) ▪ Registered Australian Body ▪ Religious Body ▪ Name Reservation ▪ Solicitor Corporation ▪ Trust
1.5	class	Complex content	Contains the class code and the associated description and it applies to entities that are registered by ASIC
1.5.1	code	nni.type:nniTypeCodeType	Code – description list of values: LMGT – Limited by guarantee LMSH – Limited by shares LMSG – Limited by shares and guarantees NLIA – No liability UNLM - Unlimited NONE – Does not have an equivalent Australian liability UNKN – Unknown
1.5.5	description	xs:string	As above
1.6	subclass	Complex content	Contains the subclass code and the associated description and it applies to entities that are registered by ASIC
1.6.1	code	nni.type:nniTypeCodeType	Code - description HUNT - Proprietary – home unit company PNPC - Proprietary – non-profit company PSTC - Proprietary – superannuation trustee company PROP - Proprietary – other LISN - Company licensed under Section 383 to omit 'Limited' from its name LISS - Company licensed under Section 383 to omit 'Limited' from its name– superannuation trustee company LIST - Listed public company NLTD - Non-profit public company registered without 'Limited' in its name under Section 150 ULSN - Unlisted public – non-profit company ULSS - Unlisted public – superannuation trustee company ULST - Unlisted public company
1.6.2	description	xs:string	As above.
1.7	status	Complex content	Contains fields related with the status of the entity

Seq. No	XML Element	Type	Description
1.7.1	code	xs:string	Various codes including: DMNT Dormant DRGD Deregistered EXAD ** Under External Administration And/Or Controller Appointed ** NOAC Not Active NRGD Not Registered REGD Registered SOFF Strike-Off Action In Progress
1.7.2	description	xs:string	The description of the status associated with the code
1.7.3	isRegistered	xs:boolean	Indicates if the entity is registered with ASIC: 'true' – means that the organisation is currently registered 'false' – means that organisation is not currently registered
1.8	incorporation State	bn.types;stateTerritoryCodeType	The state in which an Australian company was taken to have been registered
1.9	placeOfIncorporation	xs:string	The place of incorporation of a foreign company.
1.10	previousState Territory	Complex content	To be provided only when the entity is/was registered with State & Territories Agencies.
1.10.1	number	xs:string	The number assigned by the state for registration of the business name
1.10.2	stateTerritory Code	bn.types;stateTerritoryCodeType	The name of the state or territory where the business name was registered
1.11	dateRegistered	xs:date	Not relevant for this message
1.12	dateRenewal	xs:date	Not relevant for this message
1.13	dateDeregistered	xs:date	Not relevant for this message
1.14	dateReview	xs:date	Not relevant for this message
1.15	jurisdiction	xs:string	Not relevant for this message
1.16	address	Complex content	Not relevant for this message
1.17	recentDocuments	Complex content	Not relevant for this message
1.18	abrEntity	Complex content	Not relevant for this message
1.19	acncFlag	xs:boolean	If true , indicates that the entity is registered with the ACNC. It is not mandatory for this information to be displayed when presenting the result of the search. If you choose to include this information, the following text must be displayed with the result of the search: This company is registered as a charity with the Australian Charities and Not-for-Profits Commission (ACNC). For further information on the charity, including the address for service, details of responsible persons (for example company directors) and financial reports, search the Charities register at www.acnc.gov.au .

9.3. MESSAGE SPECIFICATION - getNni

9.3.1. Business Overview

This web service may be used for validating or pre-filling data related to entities that are already registered with ASIC (e.g. companies, registered bodies). It allows users to retrieve details of an entity specified in the request by one of the identifiers: ABN, ACN, State Code & State Number or the ASIC internal identifier for a business name.

Request includes:

- One identifier for the entity such as a ACN/ARBN, ASIC internal identifier for business names or a combination of a State & State Number
- Start and end dates and maximum number of documents - to be used as search criteria for returning list of documents lodged with ASIC

Reply includes:

- name of the entity
- type and status of the entity
- dates of registration, deregistration, renewal or review (whichever is applicable based on the entity type)
- registered address of the entity when this information is public
- list of recent public documents (If the request does not specify the start/end dates or the maximum number of documents then the reply returns all documents up to a maximum of 50. If a maximum number of zero is specified no document list is provided)
- former names of the entity, if any
- a flag to indicate whether the entity is registered with the Australian Charities and Not-for-Profits Commission (ACNC). It is not mandatory for this information to be displayed in the result that is presented to the user.

Note that documents lodged against business name register are not publicly available and therefore are not returned by this message.

9.3.2. HTTPS Connections & WSDL

The requestor's code must establish a HTTPS connection to the appropriate endpoint using the standard port 443.

Environment	WSDL
Production	https://www.gateway.asic.gov.au/gateway/ExternalGetNniNamePortV3?WSDL
Test	https://www.gateway.uat.asic.gov.au/gateway/ExternalGetNniNamePortV3?WSDL

9.3.3. getNni Request Message

Business Document Header

The WIG provides the specification of the Business Document Header. The following table specifies the message specific data element values or any variations to the WIG.

Element Name	Instructions / Rules	Error code
MessageType	1. Mandatory , value must be "getNni"	00002
MessageVersion	Mandatory , value must be 3	00004
senderType	Mandatory, value must be "REGA"	00005
senderId	The identifier assigned by ASIC on registration	00005

Business Document Body

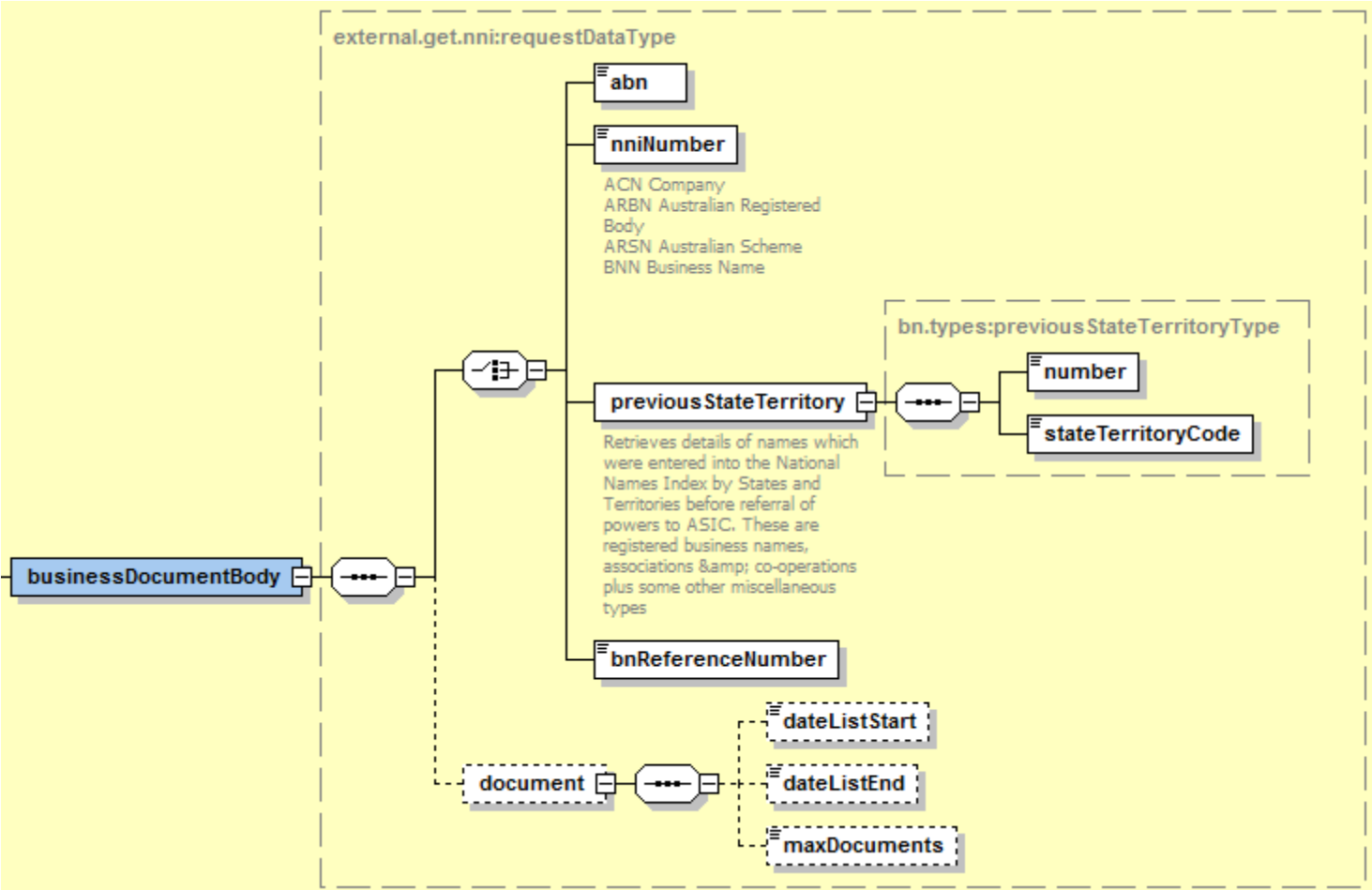

Message Content Table

Sequence No	XML Element	Type	Description	Business Rules/Instructions
1	Abn	abnType	ABN as 999999999999	The ABN must exist in ASIC register
2	nniNumber	nniNumberType	ACN or ARBN or ARSN or BNRN	The identifier must exist in ASIC register
3	previousStateTerritory	N/A	Container for previous registration details for business names (before referral of powers to ASIC) or current registration details for entities registered by States and Territories (e.g. associations; co-operatives)	N/A
3.1	Number	xs:string	The number assigned by the state for registration of the business.	Must be in a valid format as per schema (i.e. max 10 chars and contains only A-Z , 0-9 and embedded spaces)
3.2	stateTerritoryCode	stateTerritoryCodeType	The name of the state or territory where the business name was previously registered	Valid values as per enumeration: ACT; NSW; NT; QLD; SA; TAS; VIC; WA
4	bnReferenceNumber	types:bnReferenceNumberType	The Business Name Reference Number is an internal ASIC number.	Minimum length is 1 character Maximum length is 20 characters
5	Document	Complex content	Contains the search criteria for the documents to be retrieved and returned Note: The documents related to Business Names are not public information and will not be returned in this message	

5.1	dateListStart	xs:date	To search for documents that have been lodged after this date	The start date for the document list must be before the end date
5.2	dateListEnd	xs:date	To search for documents that have been lodged before this date	The start date for the document list must be before the end date
5.3	maxDocuments	xs:positiveInteger	The maximum number of public documents to be returned; this option is applicable to companies only (documents related to business names are not available to public)	A maximum of 50 recent public documents lodged can be requested to be listed

9.3.4. getNni Reply Message

Business Document Body

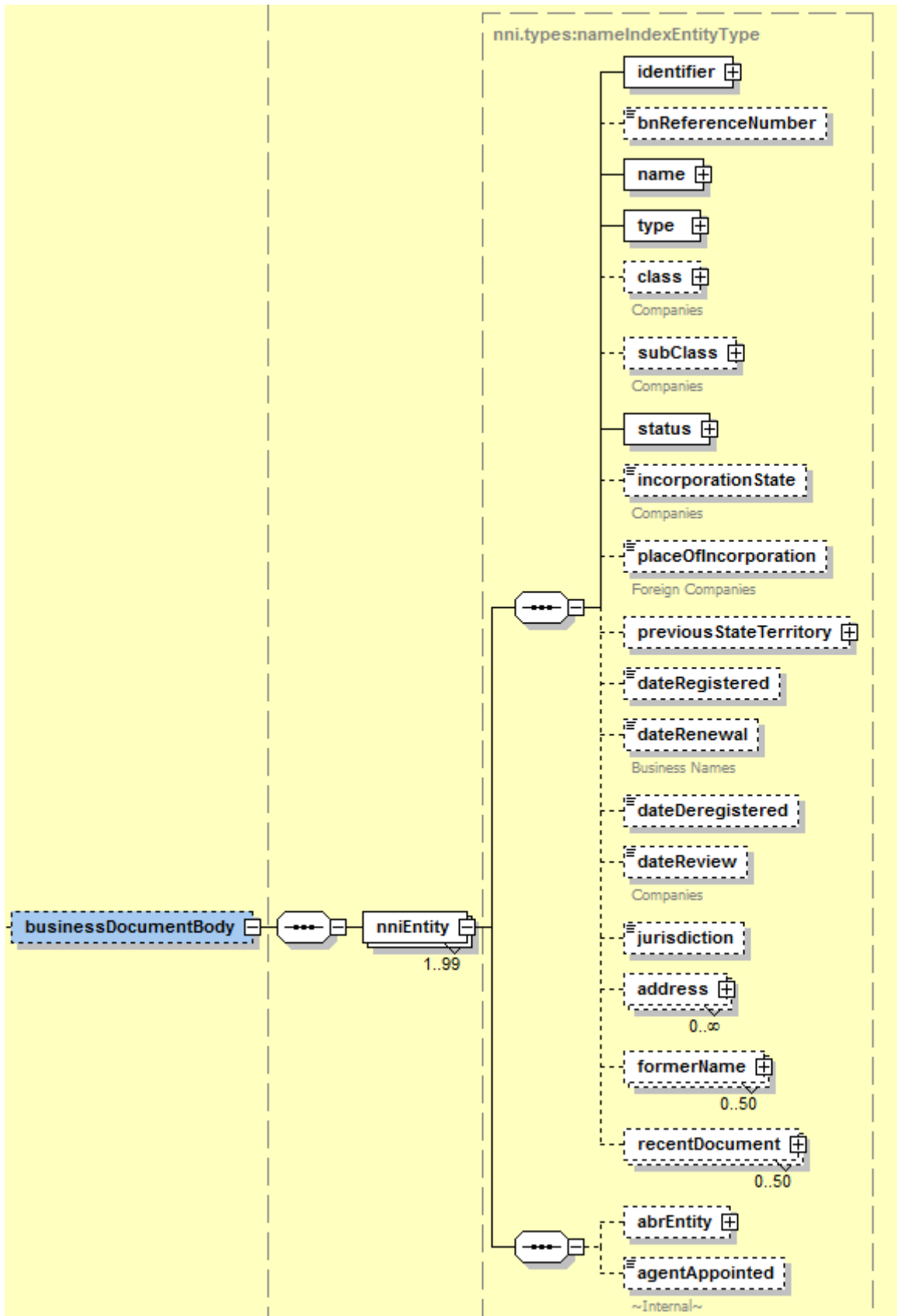

Message Content Table

Seq. No	XML Element	Type	Description
1	nniEntity	Complex content	Contains the data relevant for the entity nominated in the request
1.1	Identifier	Complex content	One of the ASIC identifiers such as ACN or ARBN or ARSN
1.1.1	numberHeading	types:numberHeadingType	Type of identifier such as: ACN – meaning Australian Company Number ARBN - meaning Australian Registered Body Number ARSN - meaning Australian Registered Scheme Number Number – used for all other types of identifiers not mentioned above
1.1.2	Number	types:nniNumberType	The value of the unique internal identifier relevant to the entity (9 digits)
1.2	bnReferenceNumber	types:bnReferenceNumberType	Not relevant to this message
1.3	Name	orgNameType	Organisation name in ASIC registry
1.3.1	Name	types:nniNameType	Entity Name
1.3.2	distinguishedWord	types:distinguishedWordType	Distinguished word – used for business names only (i.e. type =BUSN)
1.4	Type	get.nni:nniType	Contains the code and a description for the type of organisation
1.4.1	Code	xs:string	Contains a four-letter code associated with the type of entity, with the following code -descriptions: APTY - Australian Proprietary Company APUB - Australian Public Company ARPA - Australian Passport Fund ARPF - Foreign Passport Fund ASSN - Association BUSN - Business Name CHAR - Charity COMP - Community Purpose COOP - Co-Operative Society FNOS - Foreign Company (Overseas) LTDP - Limited Partnership MISM - Managed Investment Scheme NONC - Non-Company NRET - Non-Registered Entity (Nret) RACN - Registered Australian Body REBD - Religious Body RSVN - Name Reservation SOLS - Solicitor Corporation TRST - Trust
1.4.2	Description	xs:string	Contains the description of the type of entity as above
1.5	Class	Complex content	Contains the class code and the associated description and it applies to entities that are registered by ASIC

Seq. No	XML Element	Type	Description
1.5.1	Code	nni.type:nniType eCodeType	Code – description list of values: LMGT – Limited by guarantee LMSH – Limited by shares LMSG – Limited by shares and guarantees NLIA – No liability UNLM - Unlimited NONE – Does not have an equivalent Australian liability UNKN – Unknown
1.5.2	Description	xs:string	As above
1.6	Subclass	Complex content	Contains the subclass code and the associated description and it applies to entities that are registered by ASIC
1.6.1	Code	nni.type:nniType eCodeType	Code - description HUNT - Proprietary – home unit company PNPC - Proprietary – non-profit company PSTC - Proprietary – superannuation trustee company PROP - Proprietary – other LISN - Company licensed under Section 383 to omit 'Limited' from its name LISS - Company licensed under Section 383 to omit 'Limited' from its name– superannuation trustee company LIST - Listed public company NLTD - Non-profit public company registered without 'Limited' in its name under Section 150 ULSN - Unlisted public – non-profit company ULSS - Unlisted public – superannuation trustee company ULST - Unlisted public company
1.6.2	Description	xs:string	As above.
1.7	Status	statusType	Current status for the entity
1.7.1	Code	xs:string	Various codes including: DMNT Dormant DRGD Deregistered EXAD ** Under External Administration And/Or Controller Appointed ** NOAC Not Active NRGD Not Registered REGD Registered SOFF Strike-Off Action In Progress
1.7.2	Description	xs:string	The description of the status as above.
1.7.3	isRegistered	xs:boolean	Indicates if the entity is registered with ASIC and it is an interpretation of the values of status code as follows: true – if the organisation is currently registered; false – if the organisation is not currently registered

Seq. No	XML Element	Type	Description
1.8	incorporationState	types:stateTerritoryCodeType	State of incorporation – provided if the entity is currently incorporated with a State or Territory agency.
1.9	placeOfIncorporation	xs:string	Place of incorporation.
1.10	previousStateTerritory	previousStateTerritoryType	To be provided if the business was previously registered with an Australian state or territory agency
1.10.1	Number	xs:string	The number assigned by the state for previous registration of the business
1.10.2	stateTerritoryCode	xs:string	The code of the state or territory where the business name was registered previously (e.g. NSW, VIC, etc)
1.11	dateRegistered	xs:date	Date of registration for the organisation
1.12	dateDeregistered	xs:date	Date of deregistration/cancellation – provided when the entity has been deregistered or cancelled
1.13	dateRenewal	xs:date	Date of renewal
1.14	dateReview	xs:date	Date of review - provided for registered companies
1.15	Jurisdiction	xs:string	The jurisdiction under which the entity operates
1.16	Address	Complex content	Contains the address for the entity if this information is public
1.16.1	Type	types:addressTypeType	Type of address. Values that may be returned in here are : GD – meaning the address for the place of business for business names GE – meaning the address for service of documents for business names RG – meaning the registered office address for a company
1.16.2	careOf	xs:string	Not relevant to this message
1.16.3	addressLine	xs:string	Contains the address details such as street number, street name, building name, etc.
1.16.4	iso3166CountryCode	xs:string	Not relevant to this message
1.16.5	country	xs:string	The name of the country according with the ISO 3166 Country Codes
1.16.6	Street	Complex content	Not relevant to this message
1.16.6.1	streetNumber	xs:string	Not relevant to this message
1.16.6.2	streetName	xs:string	Not relevant to this message
1.16.6.3	streetType	xs:string	Not relevant to this message
1.16.7	Locality	xs:string	Locality or suburb Must be formatted in title case (ex: North Sydney)
1.16.8	postcode	xs:string	Australian postcode
1.16.9	State	types:stateTerritoryCodeType	Australian state code with valid values: ACT; NSW; NT; QLD; SA; TAS; VIC; WA
1.16.10	Override	xs:boolean	Not relevant to this message
1.16.11	Action	xs:string	Not relevant to this message
1.16.12	startDate	xs:date	Not relevant to this message

Seq. No	XML Element	Type	Description
1.16.13	endDate	xs:date	Not relevant to this message
1.16.14	documentNumber	types:nniNumberType	Not relevant to this message
1.17	formerName	Complex content	Contains the former name(s) of the organisation. Repeatable.
1.17.1	organisationName	types:nniNameType	The former name of the organisation
1.17.2	startDate	xs:date	The date that the former name started.
1.17.3	endDate	xs:date	The date that the former name ended.
1.18	recentDocument	Complex content	Contains a list of recent public documents lodged with ASIC for companies only. <i>Note: The documents related to Business Names are not public information and will not be returned in this message</i>
1.18.1	documentNumber	ascotDocumentNumberType	ASIC generated identifier to uniquely distinguish the documents lodged
1.18.2	dateReceived	xs:date	Date at which the document was accepted as fully processed by ASIC
1.18.3	formCode	xs:string	ASIC form codes – for a complete list see ASIC website: http://www.asic.gov.au/asic/asic.nsf/byheadline/Company+forms+portal?openDocument
1.18.4	numberOfPages	xs:integer	Number of pages for the pdf version of the document stored in ASIC database
1.18.5	Description	xs:string	The description associated with the form code
1.18.6	additionalDescription	Complex content	Contains additional information as a code and description.
1.18.6.1	subformCode	xs:string	ASIC subforms codes – for a complete list see ASIC website: http://www.asic.gov.au/asic/asic.nsf/byheadline/Company+forms+portal?openDocument
1.18.6.2	subformDescription	xs:string	The description associated with the subform code
1.19	abrEntity	Complex content	Contain ABN and name of the entity (if available)
1.19.1	Abn	abnType	ABN
1.19.2	abnReferenceNumber	xs:positiveInteger	Not relevant for this message
1.19.3	entityName	orgNameType	Not relevant for this message
1.19.4	entityType	xs:string	Not relevant for this message
1.19.5	effectiveDate	xs:date	Not relevant for this message
1.20	acncFlag	xs:boolean	If true , indicates that the entity is registered with the ACNC. It is not mandatory for this information to be displayed when presenting the result of the search. If you choose to include this information, the following text must be displayed with the result of the search: This company is registered as a charity with the Australian Charities and Not-for-Profits

Seq. No	XML Element	Type	Description
			Commission (ACNC). For further information on the charity, including the address for service, details of responsible persons (for example company directors) and financial reports, search the Charities register at www.acnc.gov.au .

9.4. MESSAGE SPECIFICATION - simpleFeeLookup

9.4.1. Business Overview

This web service provides the functionality to look up fee details for a nominated ASIC form code. The customer will supply the following elements:

- Form Code
- Sub Form Codes
- Date to be lodged
- Date of effect

The following table shows the valid ASIC form and sub-form code combinations used in company registration, company name reservation and business name registration.

Form Code	Sub Forms	Description
201		APPLICATION FOR REGISTRATION AS AN AUSTRALIAN COMPANY
201	201A	PUBLIC COMPANY WITH SHARE CAPITAL
201	201B	PUBLIC COMPANY LIMITED BY GUARANTEE
201	201C	PROPRIETARY COMPANY
201	201D	NAME NOT SPECIFIED IN APPLICATION
410		APPLN FOR RESERVATION OF A NAME
410	410A	NEW AUSTRALIAN COMPANY
410	410F	EXTENSION OF RESERVATION (ALL TYPES)
BZREG		BN Apply for Registration
BZREG	BZRG1	1 year
BZREG	BZRG3	3 years

9.4.2. HTTPS Connections & WSDL

The requestor's code must establish a HTTPS connection to the appropriate endpoint using the standard port 443.

Environment	WSDL
Production	https://www.gateway.asic.gov.au/gateway/ExternalSimpleFeeLookupPort?WSDL
Test	https://www.gateway.uat.asic.gov.au/gateway/ExternalSimpleFeeLookupPort?WSDL

9.4.3. *simpleFeeLookup Request Message*

Business Document Header

The WIG provides the specification of the Business Document Header. The following table specifies the message specific data element values or any variations to the WIG.

Element Name	Instructions / Rules	Error code
MessageType	Mandatory, value must be simpleFeeLookup	00002
MessageVersion	Mandatory , value must be 1	00004
senderType	Mandatory, value must be REGA	00005
senderId	The identifier assigned by ASIC on registration	00005

Business Document Body

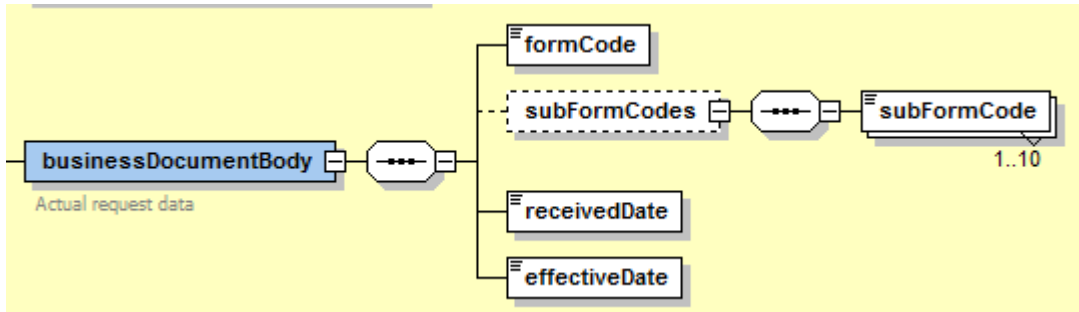

Message Content Table

Sequence No	XML Element	Type	Description	Business Rules/Instructions
1	formCode	xs:string	ASIC form code	Mandatory. Valid values are listed in the table in 9.4.1. Maximum length 5 characters
2	subFormCodes	Complex content	Contains ASIC sub-form codes	Optional, however a sub form code is required for forms 201, 410 and BZREG. Valid values are listed in the table in 9.4.1.
2.1	subFormCode	xs:string	ASIC sub-form code	Mandatory. Only valid form and sub form combinations are allowed. For example, a form code of 201 and a sub form code of 410A is an invalid combination. Form 201 can have more than one sub form, for example 201A and 201D. Maximum length 5 characters

3	receivedDate	xs:date	The date the form will be lodged	Mandatory. Must be set to the current date.
4	effectiveDate	xs:date	The date the notifications in the lodgement will have effect	Mandatory. For registration lodgements, this will be the current date.

9.4.4. simpleFeeLookup Reply Message

Business Document Body

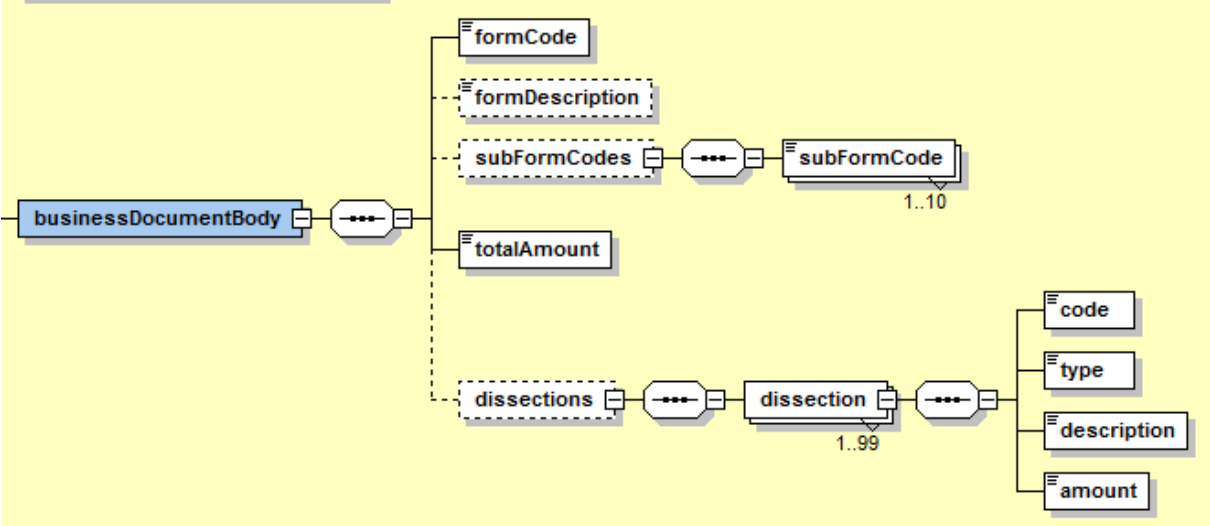

Message Content Table

Seq. No	XML Element	Type	Description
1	formCode	xs:string	Form code the fee query is made for
2	formDescription	xs:string	Description of the form Maximum length 60 characters
3	subFormCodes	Complex content	Returns the sub-form code(s) as per request
3.1	subFormCode	xs:string	ASIC sub-form code
4	totalAmount	types:amountType	Total amount calculated from request
5	Dissections	Complex content	If provided, it contains a breakdown of the fee components. Note that this is mainly relevant when late fees may be incurred, which do not apply to registration lodgements.
5.1	Dissection	Complex content	
5.1.1	Code	xs:string	Dissection code. Valid values are: I01 = Application for registration of a company with no share capital I02 = Application for registration of a company with share capital I11 = Application for registration of a company that is a superannuation trustee R01 = Application for reservation of a company name R02 = Application for extension of a company name reservation BZA = Business name application fee – 1 year BZB = Business name application fee – 3 years Maximum length 3 characters
5.1.2	Type	xs:string	Dissection types are: PF = Prescribed fee L1 = Late fee 1 L2 = Late fee 2 Maximum length 2 characters
5.1.3	Description	xs:string	Dissection description Maximum length 60 characters
5.1.4	Amount	types:amountType	Amount of the dissection

9.5. MESSAGE SPECIFICATION - initiatePayment

9.5.1. Business Overview

The initiatePayment message allows the client to notify ASIC of their intention to lodge and pay for one or more registration applications:

0 or 1 company registration and 0 to 5 business name registrations.

or

0 or 1 company name reservation

or

0 or 1 company name reservation extension

The interface will validate the request details, confirm the name availability of each registration, assess any required fees, and return a payment URL for the applicant to make a credit card payment.

Validation:

- The credentials of the lodging party will be validated as known to ASIC and correct.
- The lodging party of the input request will be authenticated as being authorised to lodge this message.
- The input and output requests will be validated against the schema defined in the WSDL and MIG.
- The Transaction Reference Number supplied in the input request will be validated as being
- new (ie, not in ASICs Staging DB), or being in ASICs Staging DB with a status of unpaid and with no applications lodged.
- Details of the lodgements will be validated against existing business rules, eg, if existing reservation details are supplied they must exist on Ascot's companies register.
- The calculated fees are compared to the fees assessed by ASIC, and if different, then the request is rejected. If calculated fees are not supplied by the client, the fees assessed by ASIC will be used.
- The proposed company and business names will be checked for name availability. If any name has a status of "Unavailable", further lodgements for this payment initiation will be prevented.

9.5.2. HTTPS Connections & WSDL

The requestor's code must establish a HTTPS connection to the appropriate endpoint using the standard port 443.

Environment	WSDL
Production	https://www.gateway ASIC.gov.au/gateway/ExternalInitiatePaymentPort?WSDL
Test	https://www.gateway.uat ASIC.gov.au/gateway/ExternalInitiatePaymentPort?WSDL

9.5.3. InitiatePayment Request Message

Business Document Header

The WIG provides the specification of the Business Document Header. The following table specifies the message specific data element values or any variations to the WIG.

Element Name	Instructions / Rules	Error code
MessageType	Mandatory, value must be initiatePayment	00002
MessageVersion	Mandatory , value must be 1	00004
senderType	Mandatory, value must be REGA	00005
senderId	The identifier assigned by ASIC on registration	00005
transactionReferenceNumber	Mandatory, value must be unique for your transactions Application transaction must be in progress	00125 00114
processMode	Indicates desired processing option. Valid values: - PROCESS – application is to be submitted for processing.	00144

Business Document Body

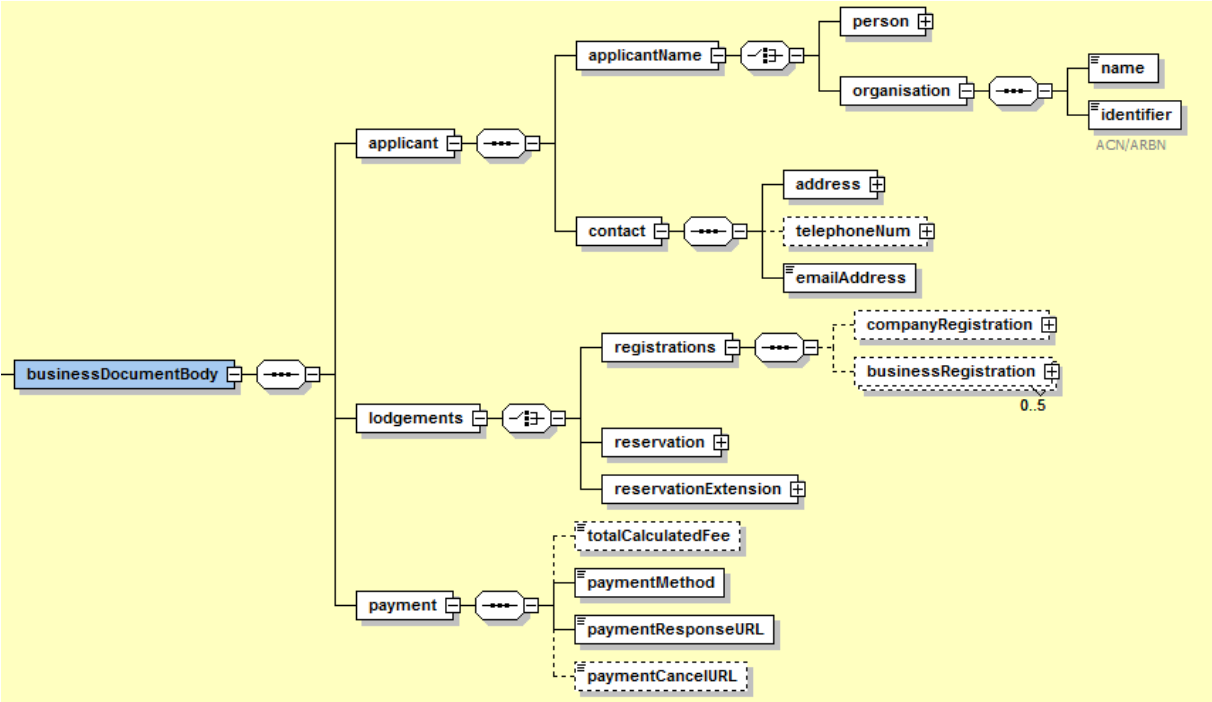

Company Registration

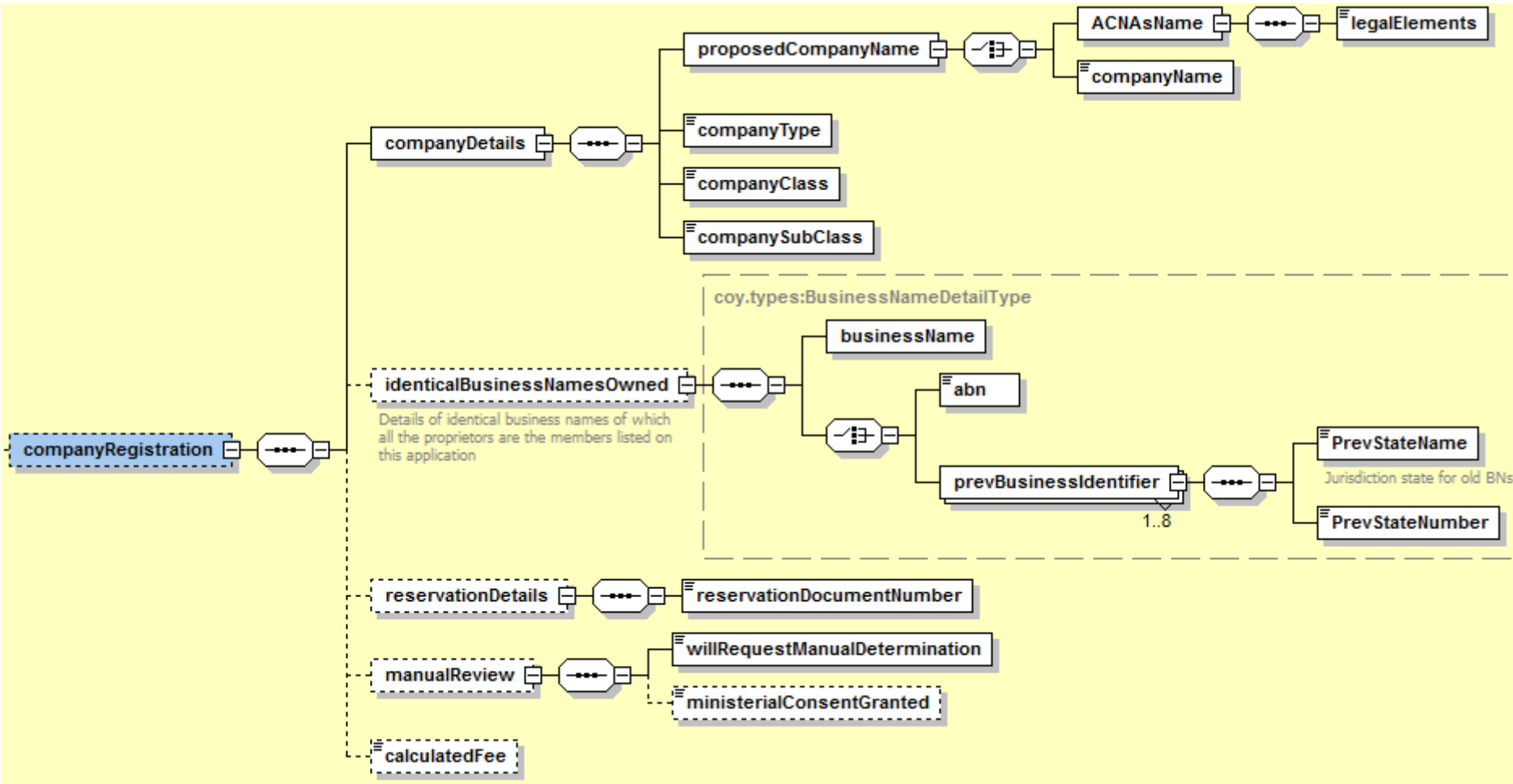

Business Name Registration

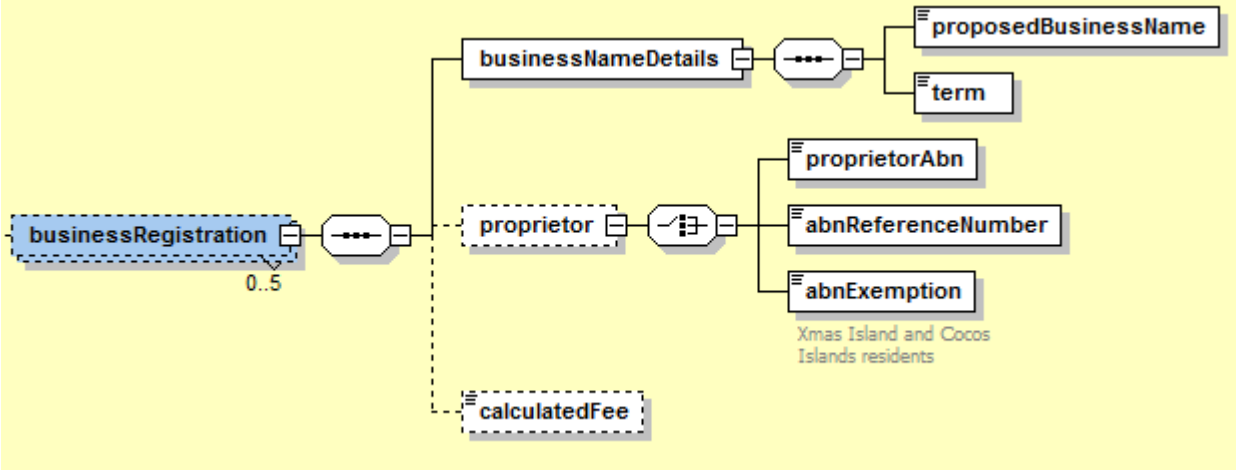

Company Name reservation

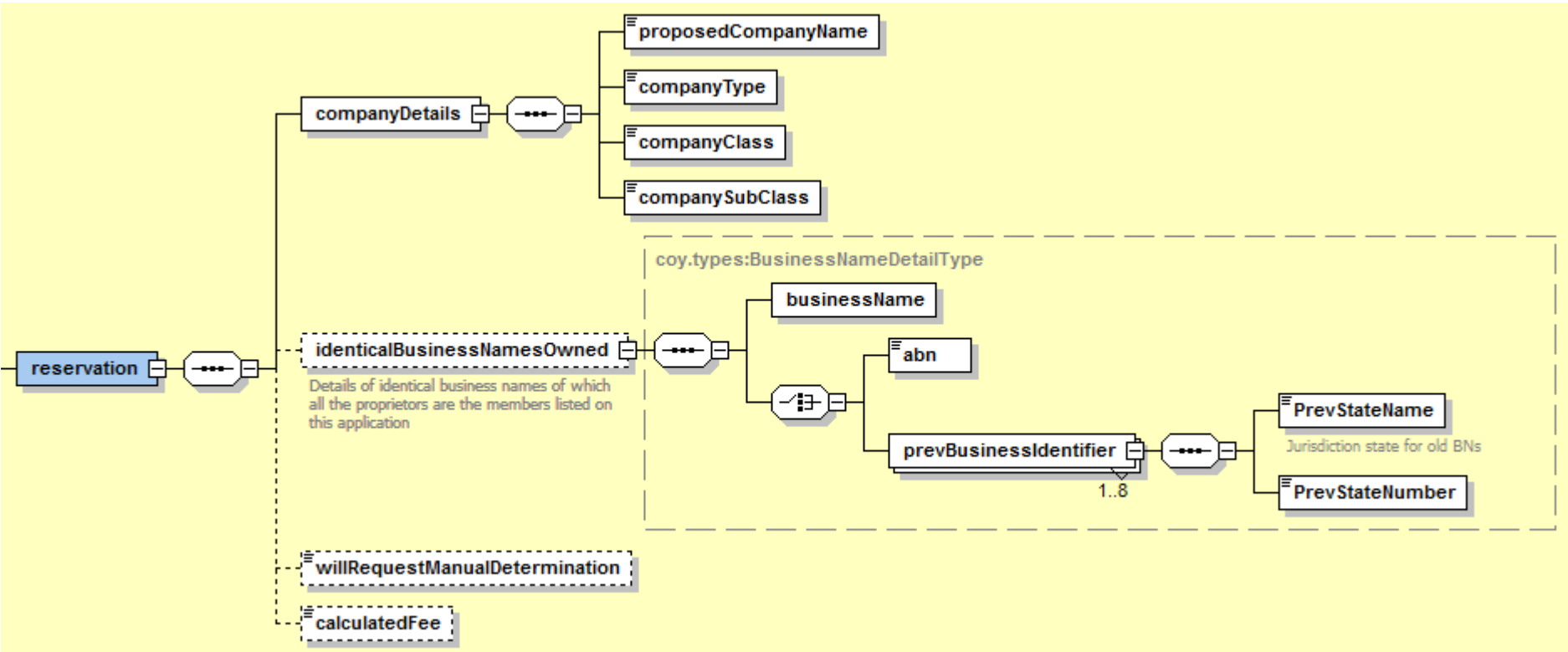

Company Name reservation Extension

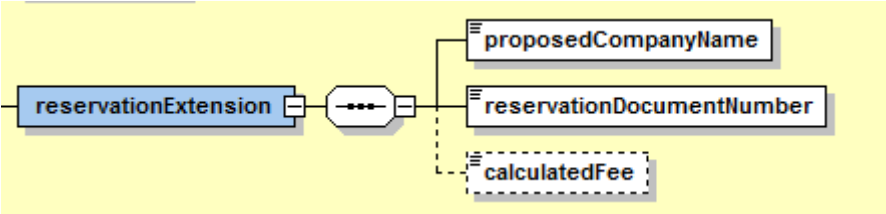

Message Content Table

Seq. No	XML Element	Type	Description	Business Rules/Instructions
1	Applicant	Complex content	Applicant name and contact details	Mandatory
1.1	applicantName	Complex content	Name of person or organisation that is the applicant	Mandatory Applicant must be either person or organisation
1.1.1	Person	types:personNameType	Container for the name of the individual that is the applicant	Mandatory if applicant is a person
1.1.1.1	givenNames	xs:string	Given name of the applicant	Mandatory Minimum length 1 characters Maximum length 140 characters
1.1.1.2	otherGivenNames	xs:string	Other given names of the applicant	Optional Minimum length 1 characters Maximum length 140 characters
1.1.1.3	familyName	xs:string	Family name of the applicant	Mandatory Minimum length 2 characters Maximum length 40 characters
1.1.2	organisation	Complex content	Applicant details if organisation	Mandatory if applicant is an organisation
1.1.2.1	Name	types:nniNameType	Applicant name if organisation	Mandatory The name must exist in ASIC records Maximum length 200 characters
1.1.2.2	Identifier	types:nniNumberType	The ACN/ARBN of the organisation	Optional If ACN/ARBN is provided, it must belong to a company that exist in the ASIC register.

1.2	Contact	Complex content	Contact details of applicant	Mandatory
1.2.1	Address	Complex content	applicant address	Mandatory
1.2.1.1	Type	types:addressType	Not relevant for this message	Not required
1.2.1.2	careOf	xs:string	Care Of	Optional
1.2.1.3	Country	xs:string	Country name as per Appendix C	Optional. If not provided it will be defaulted to "Australia"
1.2.1.4	startDate	xs:date	The date that this address started being used	Not used
1.2.1.5	DPID	xs:string	Post Office Delivery Point Identifier	Optional Maximum length 8 characters
1.2.1.6	physicalAddress	Complex content	Contains the data elements required for the Australian addresses	Mandatory Must provide a physical address; an unstructured address or a semi-structured physical address
1.2.1.6.1	floorNumber	xs:string	The level of the building	Optional Maximum length 20 characters
1.2.1.6.2	propertyName	xs:string	The name of the property	Optional Maximum length 75 characters

1.2.1.6.3	unitOrOfficeNumber	xs:string	The unit number	Optional Maximum length 20 characters
1.2.1.6.4	streetNumber	xs:string	The street number	Optional Maximum length 20 characters
1.2.1.6.5	streetName	xs:string	Street name	Optional Maximum length 75 characters
1.2.1.6.6	streetType	xs:string	Street type	Must be a valid type - the list of valid values is available in Appendix C – LIST OF Values
1.2.1.6.7	postalDeliveryType	xs:string	The postal delivery type (e.g. PO Box, Locked Bag, etc)	Optional Must be a valid type – the list of values is available in Appendix C – List of Values
1.2.1.6.8	postalDeliveryNumber	xs:string	The number associated with the postal delivery type	Defined in schema as Optional. This element is mandatory for only certain postalDeliveryType enumerations Refer to Appendix C for list of postalDeliveryTypes that require a postalDeliveryNumber
1.2.1.6.9	Locality	xs:string	Locality or suburb	Mandatory Maximum length 75 characters Must be formatted in title case (ex: North Sydney)
1.2.1.6.10	State	types:stateTerritoryCodeType	Australian state code	Mandatory, valid values are: ACT; NSW; NT; QLD; SA; TAS; VIC; WA
1.2.1.6.11	Postcode	xs:string	Australian postcode	Mandatory
1.2.1.7	unstructuredAddress	Complex content	Container for a foreign addresses	Conditional – Must be used if the address is a foreign address

				Must provide a physical address; an unstructured address or a semi-structured physical address
1.2.1.7.1	addressLine1	xs:string	Contains the details of the address such as street number, building name	Mandatory Maximum length 60 characters
1.2.1.7.2	addressLine2	xs:string	Contains the details of the address such as street name, suburb, postcode.	Mandatory Maximum length 60 characters
1.2.1.7.3	addressLine3	xs:string	Optional	Optional Maximum length 60 characters
1.2.1.7.4	addressLine4	xs:string	Optional	Optional Maximum length 60 characters
1.2.1.8	semiStructuredPhysicalAddress	Complex content	Contains a semi structured Australian address	Mandatory Must provide a physical address; an unstructured address or a semi-structured physical address
1.2.1.8.1	addressLine1	xs:string	Contains the details of the address such as street number, street name	Mandatory Maximum length 60 characters
1.2.1.8.2	addressLine2	xs:string	Optional	Optional Maximum length 60 characters
1.2.1.8.3	Locality	xs:string	Locality or suburb	Mandatory Maximum length 75 characters Must be formatted in title case (ex: North Sydney)
1.2.1.8.4	State	types:stateTerritoryCodeType	Australian state code	Mandatory, valid values are: ACT; NSW; NT; QLD; SA; TAS; VIC; WA

1.2.1.8.5	Postcode	xs:string	Australian postcode	Mandatory
1.2.2	telephoneNum	types:telephoneNumberType	Applicant's contact telephone details	Optional
1.2.2.1	telephoneNumber	Complex content	Telephone number	Mandatory
1.2.2.1.1	Prefix	xs:string	Telephone number prefix, eg country code or area code	Optional Country code
1.2.2.1.2	Number	xs:string	Telephone number	Mandatory Telephone number
1.2.2.2	phoneType	xs:string	Telephone number type	Mandatory Valid values: - Home - Mobile - Work
1.2.3	emailAddress	types:emailType	Applicant's contact email address. This is private data and is not publically available.	Mandatory Minimum length 1 characters Maximum length 200 characters This will be used as the preferred address for correspondence related to this payment
2	lodgements	Complex content	Details of lodgements that are being paid	Mandatory Lodgements can consist of registrations; reservation or reservation extension
2.1	registrations	Complex content	Details of companies and business names registration applications to be paid	Conditional – Required if the lodgement consist of company and/or business name registrations.
2.1.1	companyRegistration	Complex content	Details of company registrations to be paid	Optional Must be completed if payment includes a lodgement of a company registration (companyLodgement)

				<p>The details provided for a company registration must match the details to be lodged in the companyLodgement transaction.</p> <p>To proceed with payment, the proposed company name must pass name determination unless a manual determination has been requested.</p>
2.1.1.1	companyDetails	Complex content	Proposed name, type, class and subclass of the company to be registered	Mandatory
2.1.1.1.1	proposedCompanyName	Complex content	The details of the proposed name of the company to be registered	Mandatory
2.1.1.1.1.1	ACNAsName	Complex content	Contains the prefix and legal element details of proposed company if company is using the ACN as name	<p>Conditional</p> <p>If provided – means that the ACN is to be used as the name. The companyName element must not be completed</p> <p>Not provided – means that the ACN is not to be used as company name. The companyName element must be completed</p>
2.1.1.1.1.1.1	legalElements	xs:string	The legal elements of the proposed company	<p>Mandatory</p> <p>Minimum length 1 characters</p> <p>Maximum length 20 characters</p> <p>Refer to Appendix E for valid legal element combinations</p>
2.1.1.1.1.2	companyName	Complex content	The proposed company name details	<p>Conditional</p> <p>Either ACNAsName details are provided or companyName is entered.</p> <p>It can contain up to valid 200 chars, including spaces and legal elements.</p> <p>Must contain valid characters:</p> <p>A to Z</p> <p>0 to 9</p> <p>!@#\$%^&*“()?;:</p> <p>=_-\./\.,‘{ } </p>

2.1.1.1.2	companyType	xs:string	The type of the proposed company	Mandatory Valid codes are: APTY – Australian Proprietary Company APUB – Australian Public Company Refer to Appendix E for valid company type/class/subclass combinations
2.1.1.1.3	companyClass	xs:string	The class of the proposed company	Mandatory Valid codes are: LMGT – Limited by guarantee LMSH – Limited by shares NLIA – No liability Refer to Appendix E for valid company type/class/subclass combinations
2.1.1.1.4	companySubClass	xs:string	The subclass of the proposed company	Mandatory Valid codes are: PNPC – Proprietary charitable purposes only PSTC – Proprietary superannuation trustee company HUNT – Proprietary home unit company PROP – Proprietary other ULSN – Unlisted public – charitable purposes only ULSS – Unlisted public – superannuation trustee company ULST – Unlisted public company Refer to Appendix E for valid company type/class/subclass combinations
2.1.1.2	identicalBusinessNamesOwned	Complex content	Details of the business names that are identical to the company name being registered	Optional If the business name is not registered under an ABN holder or is exempt from registering under an ABN holder, or is a joint venture structure, set "willRequestManualDetermination" to "true".

2.1.1.2.1	businessName	types:nniNameType	Business name	Mandatory The business name must exist in ASIC register
2.1.1.2.2	Abn	abnType	ABN of the business name holder	Conditional If there is a business name entered, provided either ABN or state business name details (prevBusinessIdentifier elements) The ABN must exist in ASIC register
2.1.1.2.3	prevBusinessIdentifier	Complex content	Details of previous state business name registrations.	Conditional If there is a business name entered, provided either ABN or state business name details (prevBusinessIdentifier elements) Details of up to 8 business names identical to the company name to be registered can be provided
2.1.1.2.3.1	PrevStateName	types:stateTerritoryCodeType	The state in which the BN was previously registered.	Mandatory Must be one of the following values: ACT; NSW; NT; QLD; SA; TAS; VIC; WA
2.1.1.2.3.2	PrevStateNumber	xs:string	The number assigned by the state for registration of the business name	Mandatory Maximum of 10 characters
2.1.1.3	reservationDetails	Complex content	Details of name reservation if company name has been reserved	Optional
2.1.1.3.1	reservationDocumentNumber	xs:string	Contains the ASIC document number of the current name reservation.	Mandatory Length is 9 characters. The company name reservation must still be current. The reserved company name/type/class must match to the company registration details.
2.1.1.4	manualReview	Complex content	Contains details of manual review requests	Optional Manual determination will be required if: <ul style="list-style-type: none"> - ASIC consent is required to use the proposed company name; - Ministerial consent is required;

				<ul style="list-style-type: none"> - Query name availability on the proposed company name returns a rejected name result and the applicant wish to proceed with the name; - The proposed name is identical to a business name that is not registered under an ABN entity holder. <p>If the application is required to be manually reviewed, set the request for manual determination to 'true'.</p>
2.1.1.4.1	willRequestManualDetermination	types:trueType	Request application be manually reviewed	Mandatory Set value to true.
2.1.1.4.2	ministerialConsentGranted	types:trueType	ASIC's approval in case of the ministerial consent was granted	Optional
2.1.1.5	calculatedFee	types:amountType	The expected fee for the application of a company registration	Optional If provided, it must be equal to ASIC's calculated fee for this application, otherwise an error will be returned.
2.1.2	businessRegistration	Complex content	Details of the business name registration applications to be paid	Conditional Must be completed if payment is for lodgement of business name registration (bnLodge) A maximum of 5 BN registration applications may be paid in one transaction The details provided for the business name registration(s) must match the details to be lodged in the bnLodge transaction(s). To proceed with payment, the proposed business name(s) must pass name determination unless a manual determination has been requested.
2.1.2.1	businessNameDetails	Complex content	Contains the proposed business name	Mandatory

2.1.2.1.1	proposedBusinessName	types:nniNameType	The proposed business name	Mandatory Must match the name in bnLodge It can contain up to valid 200 chars, including spaces. Must contain valid characters: A to Z 0 to 9 ! @ # \$ % ^ & * " () ? ; : = _ - / \ . , ' { }
2.1.2.1.2	Term	xs:string	The initial period of registration for the new business name that may be for one year or three years.	Mandatory Valid values are 1 or 3
2.1.2.2	Proprietor	Complex content	The proprietor details of the intended business name	Conditional as follows: - Not required if the holder of the business name(s) will be the proposed company. - Otherwise, mandatory. Provide ABN or ABN reference of proprietor; or advise if holder is exempted from holding an ABN
2.1.2.2.1	proprietorAbn	types:abnType	ABN for the holder of new business names whose other names may be similar or nearly identical to the proposedName.	Mandatory 1. The ABN provided must exist in ABR register 2. The status of the entity owning the ABN in ABR register must be 'current'
2.1.2.2.2	abnReferenceNumber	xs:positiveInteger	ABR Reference Number provided when an application for ABN is lodged with ABR, if the ABN is not granted immediately	Mandatory The ABN reference must be valid in ABR register
2.1.2.2.3	abnExemption	types:trueType	Indicates that the holder is exempted from holding an ABN under one of the two scenarios: • joint venture or Christmas Island and Cocos islands entities	Mandatory Valid value is 'true' if holder is exempted from holding an ABN (i.e. the entities type Joint venture or the entities from Cocos Islands and Christmas Island
2.1.2.3	calculatedFee	types:amountType	The expected fee for the total number of business name registration(s)	Optional If provided, it must be equal to ASIC's calculated fee for the application(s), otherwise an error will be returned.

2.2	reservation	Complex content	Details of the company name reservation applications to be paid	Conditional – Required if the lodgement is an application for a company name reservation. The details provided for a company name reservation must match the details to be lodged in the rsvnLodge transaction.
2.2.1	companyDetails	Complex content	Proposed name, type, class and subclass of the company to be reserved	Mandatory
2.2.1.1	proposedCompanyName	types:nniNameType	The proposed company name to be reserved	Mandatory It can contain up to valid 200 chars, including spaces and legal elements. Must contain valid characters: A to Z 0 to 9 ! @ # \$ % ^ & * " () ? ; : = _ - / \ . , ' { }
2.2.1.2	companyType	xs:string	The type of the proposed company	Mandatory Valid codes are: APTY – Australian Proprietary Company APUB – Australian Public Company Refer to Appendix E for valid company type/class/subclass combinations
2.2.1.3	companyClass	xs:string	The class of the proposed company	Mandatory Valid codes are: LMGT – Limited by Guarantee LMSH – Limited by Shares NLIA – No Liability Refer to Appendix E for valid company type/class/subclass combinations

2.2.1.4	companySubClass	xs:string	The subclass of the proposed company	Optional Valid codes are: PNPC – Proprietary Non Profit Company PSTC – Proprietary Superannuation Trustee Company HUNT – Proprietary Home Unit Company PROP – Proprietary other ULSN – Unlisted Public – Non Profit Company ULSS – Unlisted Public – Superannuation Trustee Company ULST – Unlisted Public Company Refer to Appendix E for valid company type/class/subclass combinations
2.2.2	identicalBusinessNamesOwned	Complex content	Details of the identical business name that is to be reserved as a company name	Optional
2.2.2.1	businessName	types:nniNameType	Business name	Mandatory The business name must exist in ASIC register It can contain up to valid 200 chars, including spaces. Must contain valid characters: A to Z 0 to 9 !@#\$%^&*“()?;: =_-/\.,‘{ }
2.2.2.2	ABN	abnType	ABN of the business name holder	Conditional If there is a business name entered, provided either ABN or state business name details (prevBusinessIdentifier elements) The ABN must exist in ASIC register
2.2.2.3	prevBusinessIdentifier	Complex content	Details of previous state business name registrations.	Conditional

				If there is a business name entered, provided either ABN or state business name details (prevBusinessIdentifier elements) Details of up to 8 business names identical to the company name to be reserved can be provided
2.2.2.3.1	PrevStateName	types:stateTerritoryCodeType	The state in which the BN was previously registered.	Mandatory Must be one of the following values: ACT; NSW; NT; QLD; SA; TAS; VIC; WA
2.2.2.3.2	PrevStateNumber	xs:string	The number assigned by the state for registration of the business name	Mandatory Maximum of 10 characters
2.2.3	willRequestManualDetermination	types:trueType	Request application be manually reviewed	Optional Manual determination will be required if: <ul style="list-style-type: none"> - ASIC consent is required to use the proposed company name; - Ministerial consent is required; - Query name availability on the proposed company name returns a rejected name result and the applicant wish to proceed with the name; - The proposed name is identical to a business name that is not registered under an ABN entity holder. If the application is required to be manually reviewed, set the request for manual determination to 'true'.
2.2.4	calculatedFee	types:amountType	The expected fee for the reservation of a company name	Optional If provided, it must be equal to ASIC's calculated fee for the application, otherwise an error will be returned.
2.3	reservationExtension	Complex content	Details of the company name reservation extension to be paid	Conditional - Required if the lodgement is an application for an extension of a company name reservation.

				The details provided for a company name reservation extension must match the details to be lodged in the rsvnLodge transaction.
2.3.1	proposedCompany Name	xs:string	The reserved company name	Mandatory Must exist in ASIC register It can contain up to valid 200 chars, including spaces and legal elements. Must contain valid characters: A to Z 0 to 9 !@#\$%^&*“()?;: =_-/\.,‘{ }
2.3.2	reservationDocumentNumber		Document number of form 410 that originally reserved the name	Mandatory Must exist in ASIC register. The company name reservation must be current.
2.3.3	calculatedFee	types:amountType	The expected fee for the extension of a company name reservation,	Optional If provided, it must be equal to ASIC's calculated fee for the application, otherwise an error will be returned.
3	payment	Complex content	Contains details of the payment to be made	Mandatory
3.1	totalCalculatedFee	types:amountType	The expected total amount to be paid	Optional If provided, it must be equal to ASIC's calculated total fee for the application(s), otherwise an error will be returned.
3.2	paymentMethod	types:paymentMethodType	Payment method	Mandatory Must be CC (Credit Card)
3.3	paymentResponseURL	xs:string	Payment response URL	Mandatory Maximum 512 characters This is the URL that the payment provider will redirect to after payment attempt

3.4	paymentCancelURL	xs:string	Payment cancel response URL	<p>Optional Maximum 512 characters If provided, and the payment is cancelled, this is the URL that the payment provider will redirect to. If not provided, the payment provider will redirect the user to the 'paymentResonseURL'.</p>
-----	------------------	-----------	-----------------------------	---

9.5.4. *initiatePayment Reply Message*

Business Document Body

Company and Business Name Registration

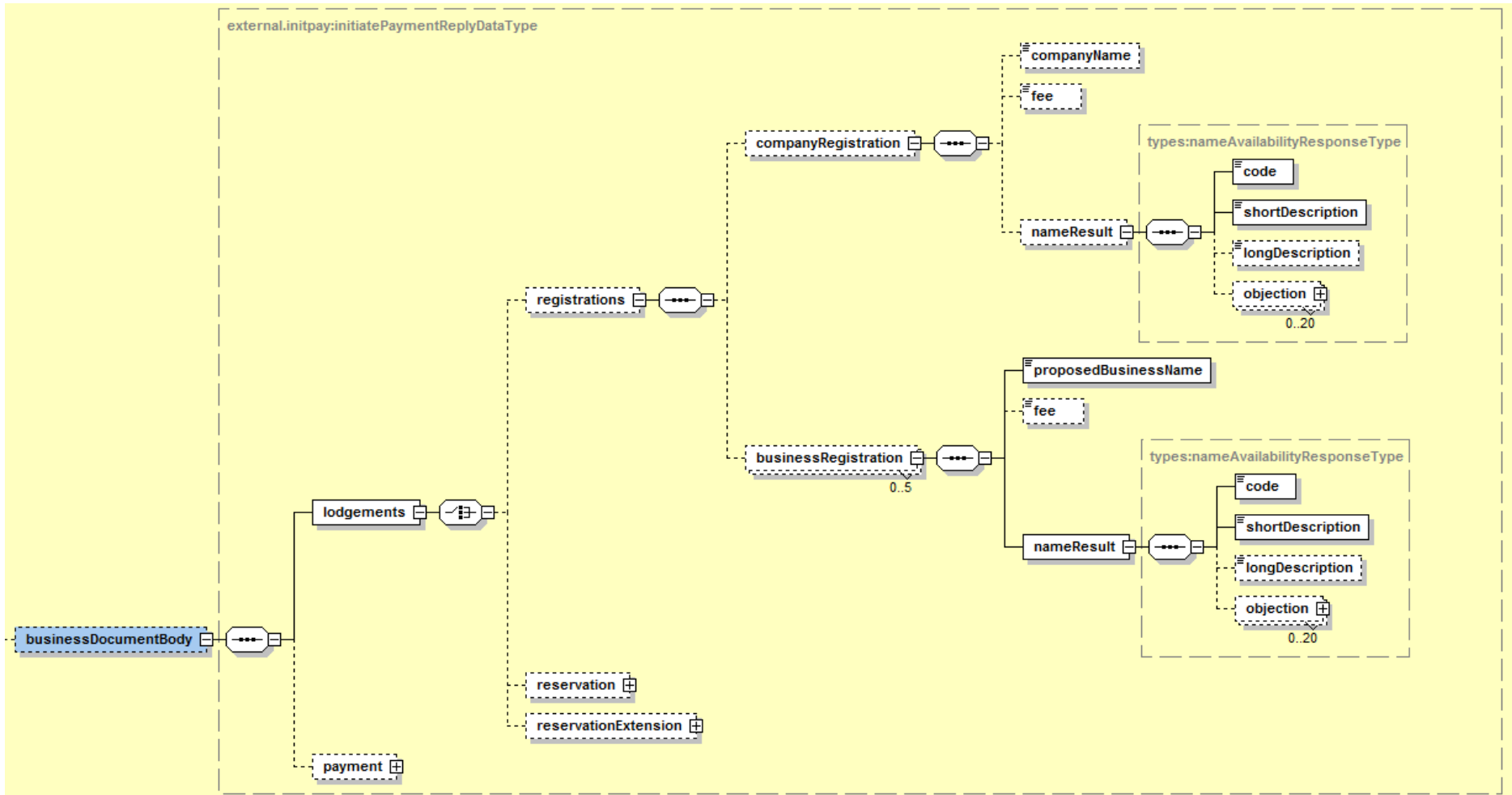

Reservation, Reservation Extension and Payment

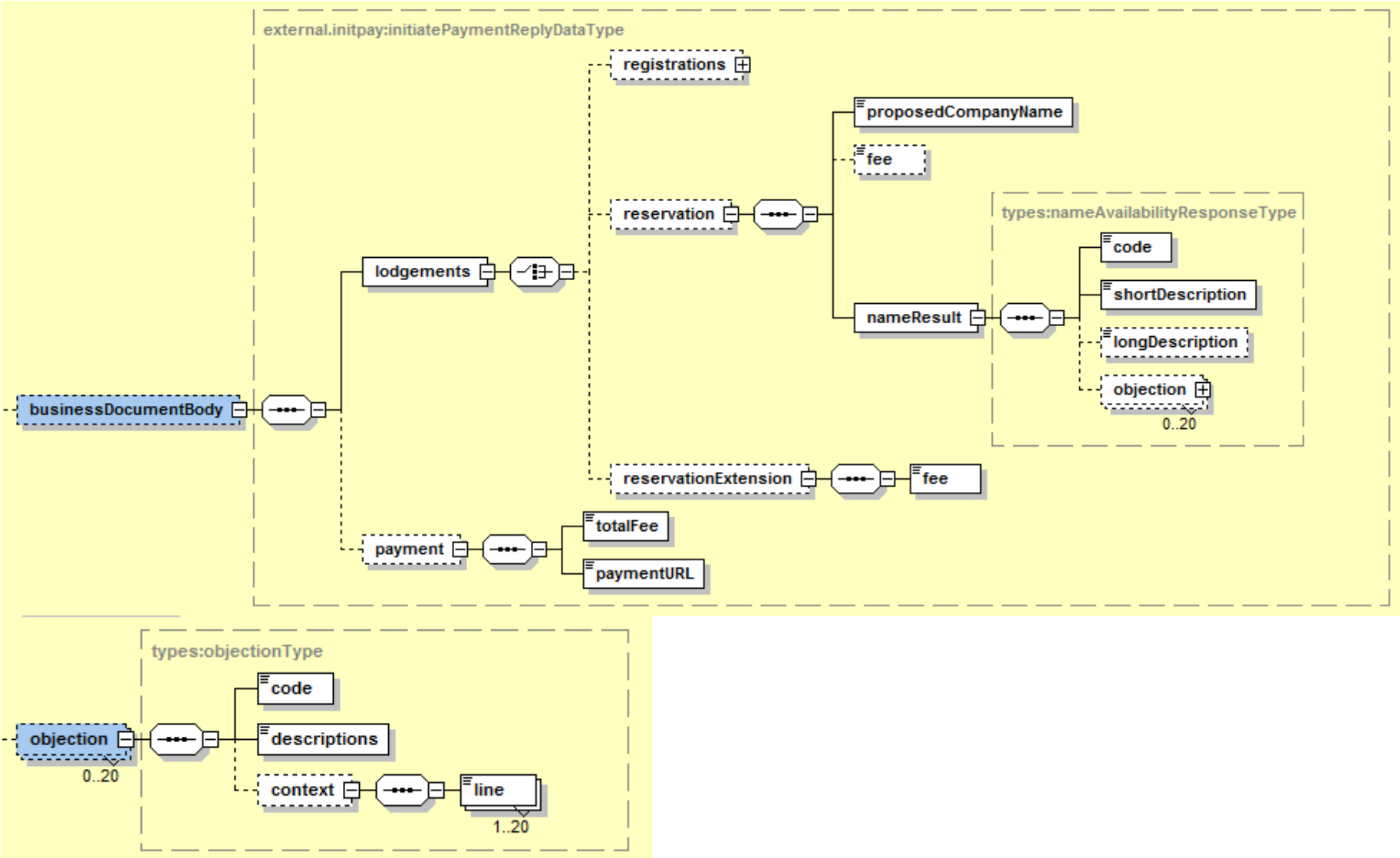

Message Content Table

Seq. No	XML Element	Type	Description
1	lodgements	Complex content	Mandatory Contains details of lodgements paid for
1.1	registrations	Complex content	Conditional Will be populated with proposed company and/or BN registration request results and fee
1.1.1	companyRegistration	Complex content	Conditional>Returns the company registration payment request result
1.1.1.1	companyName	xs:string	Optional Name of the proposed company name if ACN not used as the company name
1.1.1.2	fee	types:amountType	Optional Amount payable for the company registration The fee amount is only returned if the company name is available or if there is a request for manual name determination
1.1.1.3	nameResult	Complex content	Indicates the result of the name assessment for the proposed company upon submitting the application. This validation will return a similar result as the queryNameAvailability service.
1.1.1.3.1	code	xs:string	Will return one of the following valid values : Available –the name is available to be used as a company name Unavailable –the name can't be used and the user should propose another name SubjectToNamesDetermination –the name is referred to ASIC staff for manual determination
1.1.1.3.2	shortDescription	xs:string	A short text description associated with the code (as listed above) and it provides the result of the name availability check done as part of the validations for the application being submitted
1.1.1.3.3	longDescription	xs:string	A long text description associated with the codes (as listed above) and it provides the result of the name availability check done as part of the validations for the application being submitted
1.1.1.3.4	objection	Complex content	Returned only when the proposed name is unavailable or it is subject to name determination. It contains a code and a description and indicates the reason for the decision.

1.1.1.3.4.1	code	xs:string	<p>The code used by ASIC for the objections. It is returned only if the name is unavailable or is referred to manual processing.</p> <p>Refer to appendix E for some examples of likely name availability objection codes.</p> <p>Please note that is best to develop a generic process to display the code and description as opposed to hard coding these. ASIC may in time choose to tweak or embellish upon the objection descriptions.</p>
1.1.1.3.4.2	descriptions	xs:string	The description associated with the code of the objections.
1.1.1.3.4.3	context	Complex content	Additional information returned when the name is identical or near identical to another existing name.
1.1.1.3.4.4	line	xs:string	<p>The code used by ASIC for the objections. It is returned only if the name is unavailable or is referred to manual processing.</p> <p>Refer to appendix E for some examples of likely name availability objection codes.</p> <p>Please note that is best to develop a generic process to display the code and description as opposed to hard coding these. ASIC may in time choose to tweak or embellish upon the objection descriptions.</p>
1.1.2	businessRegistration	Complex content	Conditional Returns the business name registration payment request result
1.1.2.1	proposedBusinessName	xs:string	Additional information returned when the name is identical or near identical to another existing name.
1.1.2.2	fee	types:amountType	Optional Amount payable for the business name registration(s) The fee amount is only returned if the business names are available or if there is a request for manual name determination
1.1.2.3	nameResult	Complex content	Indicates the result of the name assessment for the proposed business name upon submitting the application. This validation will return a similar result as the queryNameAvailability service.
1.1.2.3.1	code	xs:string	<p>Will return one of the following valid values :</p> <p>Available –the name is available to be used as a business name</p> <p>Unavailable –the name can't be used and the user should propose another name</p> <p>SubjectToNamesDetermination –the name is referred to ASIC staff for manual determination</p>

			<p>UnderTransfer –the name has been previously cancelled with the intention to transfer to another holder</p> <p>Identical – meaning the name is identical to another name and it may be rejected</p>
1.1.2.3.2	shortDescription	xs:string	A short text description associated with the code (as listed above) and it provides the result of the name availability check done as part of the validations for the application being submitted
1.1.2.3.3	longDescription	xs:string	A long text description associated with the codes (as listed above) and it provides the result of the name availability check done as part of the validations for the application being submitted
1.1.2.3.4	objection	xs:string	Returned only when the proposed name is unavailable or it is subject to name determination. It contains a code and a description and indicates the reason for the decision.
1.1.2.3.4.1	code	xs:string	<p>The code used by ASIC for the objections. It is returned only if the name is unavailable or is referred to manual processing.</p> <p>Refer to appendix E for some examples of likely name availability objection codes.</p> <p>Please note that is best to develop a generic process to display the code and description as opposed to hard coding these. ASIC may in time choose to tweak or embellish upon the objection descriptions.</p>
1.1.2.3.4.2	descriptions	xs:string	The description associated with the code of the objections.
1.1.2.3.4.3	context	Complex content	Additional information returned when the name is identical or near identical to another existing name.
1.1.2.3.4.1	line	xs:string	Contains the ASIC internal identifier for a business name or Australian Company Number and the company name that resulted in the exact match (i.e. the existing registered name).
1.2	reservation	Complex content	<p>Conditional</p> <p>Returns the company name reservation payment request result</p>
1.2.1	proposedCompanyName	xs:string	<p>Mandatory</p> <p>Name of company to be reserved</p>
1.2.2	fee	types:amountType	<p>Optional</p> <p>Amount payable for the company name reservation</p> <p>The fee amount is only returned if the proposed company name is available or if</p>

			there is a request for manual name determination
1.2.3	nameResult	xs:string	Indicates the result of the name assessment for the proposed company name reservation upon submitting the application. This validation will return a similar result as the queryNameAvailability service.
1.2.3.1	code	xs:string	Will return one of the following valid values : Available –the name is available to be used as a company name Unavailable –the name can't be used and the user should propose another name SubjectToNamesDetermination –the name is referred to ASIC staff for manual determination
1.2.3.2	shortDescription	xs:string	A short text description associated with the code (as listed above) and it provides the result of the name availability check done as part of the validations for the application being submitted
1.2.3.3	longDescription	xs:string	A long text description associated with the codes (as listed above) and it provides the result of the name availability check done as part of the validations for the application being submitted
1.2.3.4	objection	xs:string	Returned only when the proposed name is unavailable or it is subject to name determination. It contains a code and a description and indicates the reason for the decision. Repeatable 20 times
1.2.3.4.1	code	xs:string	The code used by ASIC for the objections. It is returned only if the name is unavailable or is referred to manual processing. Refer to appendix E for some examples of likely name availability objection codes. Please note that is best to develop a generic process to display the code and description as opposed to hard coding these. ASIC may in time choose to tweak or embellish upon the objection descriptions.
1.2.3.4.2	descriptions	xs:string	The description associated with the code of the objections.
1.2.3.4.3	context	Complex content	Additional information returned when the name is identical or near identical to another existing name.
1.2.3.4.1	line	xs:string	Contains the ASIC internal identifier for a business name or Australian Company Number and the company name that resulted in the exact match (i.e. the existing registered name).

1.3	reservationExtension	Complex content	Conditional Returns the extension of company name reservation payment request result
1.3.1	fee	types:amountType	Optional Amount payable for the company name reservation extension
2	payment	Complex content	Conditional Payment details is only returned if the proposed names are available or are under name determination
2.1	totalFee	types:amountType	Mandatory Total amount payable
2.2	paymentURL	xs:string	Mandatory Maximum 512 characters Provides the URL for the ASIC Payment Gateway request.

9.6. MESSAGE SPECIFICATION - bnLodgeApplication

9.6.1. Business Interaction Overview

This web service allows the lodgement of an application for registration of a Business Name. The entity applying for the business name must have a current ABN or it must have applied for an ABN and provide a valid ABR reference number (excluding the entities from Cocos Island and Christmas Island that are exempt from this requirement).

The message can be used for the following applications:

- I. registration of a new business name
- II. registration of a business name where the previous holder cancelled the business name and agreed to transfer the name to a new business name holder - in this case the applicant must be able to supply the transfer key provided by the previous holder

Request includes:

- the Transaction Reference Number, in the Business Document Header
- the ABN or the ABN reference number for the entity that is applying for a business name (i.e. the holder of the business name)
- the proposed business name
- the period of registration for the new business name
- details of the business name holder applying for the new business name
- the principal place of business address
- the address for the service of documents
- email address for the ongoing contact for the business
- signatory information containing the name of the person applying for the business name
- transfer key - optionally, for names that are to be transferred

The type of data captured for a business name holder varies considerably depending on the owning entity structure. ASIC's description of these four types and the data capture matrix is shown in the table below:

ASIC Type	Description	Details collected
Individual	Person that is registered with the ABR as a sole trader	<ul style="list-style-type: none"> • Name of the holder • ABN • DOB and POB • Residential address • Email (optional)
Incorporated body	<p>Public or private companies incorporated with ASIC or registered bodies registered with ASIC.</p> <p>Note: the Other Incorporated bodies that can't supply an ACN or ARBN will be considered 'unincorporated' for the purpose of this MIG and must provide more details upon registration (refer to "Unincorporated Structures" below)</p>	<ul style="list-style-type: none"> • Name of the holder • ABN • ACN/ARBN
Partnership	<p>Entities that have 2 or more partners. Partnerships are typically registered with the ABR.</p> <p>The partners may be:</p> <ul style="list-style-type: none"> • individuals • companies/registered bodies • other incorporated organisation without an ACN/ARBN (this will be treated as 'unincorporated' for the purpose of this MIG) <p>The 'unincorporated' structure must provide details of one or more organisation representatives that could be either a person or an incorporated body.</p>	<ul style="list-style-type: none"> • Name of the partnership • ABN <p><u>Details for each individual partner:</u></p> <ul style="list-style-type: none"> • Name • DOB and POB • Residential address • email (optional) <p><u>Details for each company/registered body partner:</u></p> <ul style="list-style-type: none"> • Name • ACN /ARBN • Email (optional) <p><u>Details for each organisation unincorporated partner:</u></p> <ul style="list-style-type: none"> • Name • Details of individual representative (Name, DOB, POB, Residential address, email (optional)) • Details of each company/registered body that is a representative (Name, ACN/ARBN, email (optional))

ASIC Type	Description	Details collected
<p>Joint Venture Partnership¹</p>	<p>Joint ventures do not have a single ABN at the joint venture level. Instead each joint venturer has an ABN.</p> <p>The partners of the joint venture might be:</p> <ul style="list-style-type: none"> • individuals • companies/registered bodies • other organisations (must be an incorporated body, that is legal entity) without an ACN/ARBN (this will be treated as 'unincorporated' for the purpose of this MIG) <p>The 'unincorporated' structure must provide details of one or more organisation representatives that could be either a person or an incorporated body.</p>	<ul style="list-style-type: none"> • Name for the Joint venture <p><u>Details for each individual joint venture partner:</u></p> <ul style="list-style-type: none"> • Name • ABN • DOB and POB • Residential address • Email (optional) <p><u>Details for each joint venture company/registered body: partner:</u></p> <ul style="list-style-type: none"> • Name • ABN • ACN /ARBN • Email (optional) <p><u>Details for each joint venture organisation (unincorporated) partner:</u></p> <ul style="list-style-type: none"> • Name • ABN • Details of each individual representative (Name, DOB, POB, Residential address, email (optional)) • Details of each company/registered body that is a representative (Name, ACN/ARBN, email (optional))
<p>Unincorporated Structures</p>	<p>All other entities that cannot be classified as one of the above (Individual, Incorporated Body or Partnership)</p> <p>For example: Trusts, Super Funds, Other unincorporated entities or Other Incorporated entities without an ACN/ARBN.</p> <p>The unincorporated structure has one or more organisation representatives that are either a person or an incorporated body.</p> <p>Organisation representatives must be a member of the governing body of the organisation, for example, the president, secretary or public officer of an association or other body.</p> <p>Trusts must provide details of at least one trustee.</p>	<ul style="list-style-type: none"> • Name of the holder • ABN <p><u>Details for each individual representative:</u></p> <ul style="list-style-type: none"> • Name • DOB and POB, • Residential address • Email (optional) <p><u>Details for each company/registered body representative:</u></p> <ul style="list-style-type: none"> • Name • ACN /ARBN • Email (optional)

ASIC Type	Description	Details collected
	All notified organisation representatives will be able to update details for this business name.	
Christmas Island and Cocos Island entities	Residents of the islands that are exempted from the requirement to hold an ABN (assuming that the principal place of business will be in this jurisdiction). ASIC will treat them similarly with the partnerships and therefore details of the individual or of every partner are required.	<ul style="list-style-type: none"> • Name of the holder <p><u>Details for each individual partner:</u></p> <ul style="list-style-type: none"> • Name • DOB and POB, • Residential address • Email (optional) <p><u>Details for each company/registered body partner:</u></p> <ul style="list-style-type: none"> • Name • ACN /ARBN • Email (optional) <p><u>Details for each joint venture company/registered body: partner:</u></p> <ul style="list-style-type: none"> • Name • ACN /ARBN • Email (optional) <p><u>Details for each joint venture organisation (unincorporated) partner:</u></p> <ul style="list-style-type: none"> • Name • Details of each individual representative (Name, DOB, POB, Residential address, email (optional)) • Details of each company/registered body that is a representative (Name, ACN/ARBN, email (optional))

Note that Joint ventures come in different structures. A joint venture entity with an ABN can be either a Partnership (which would be classified as a “partnership” via the ABR for the purposes of the BN application) or a corporate structure where the joint venture partners are members of the company or a Unit Trust (which would be classified as an unincorporated entity via the ABR for the purposes of the BN application). For the purposes of BN, we are separating these types of JVs from a Complex content of entities that apply for a BN each with their own ABN, which is a “Joint Venture Partnership” for the purposes of the BN application.

The mapping between ASIC business entities and the ABR entity types to be applied in building the request messages is represented in the [Appendix A](#).

Response includes:

- the result for the lodgement that indicate if the message is accepted or rejected. If rejected it will also indicate the reasons
- result of the name assessment performed after the lodgement of the application
- URL link to the PDF of the application form

When the application is received successfully ASIC is processing it and it will confirm whether the business name can be registered or not (i.e. name is available or not). When the lodgement is received, ASIC updates the public register with the new business name holder details and sends out the following correspondence:

- Record of Registration
- ASIC key

ASIC will use the email address advised in the request for correspondence regarding the applications, including delivery of certificates and notices.

9.6.2. **HTTPS Connections & WSDL**

The requestor's code must establish a HTTPS connection to the appropriate endpoint using the standard port 443.

Environment	WSDL
Production	https://www.gateway.asic.gov.au/gateway/ExternalBz1PortV2?WSDL
Test	https://www.gateway.uat.asic.gov.au/gateway/ExternalBz1PortV2?WSDL

9.6.3. **bnLodgeApplication Request Message**

Business Document Header

The WIG provides the specification of the Business Document Header. The following table specifies the message specific data element values or any variations to the WIG.

Note that this message is updating data in ASIC register and we advise to implement the functionality described in the section “Duplicate transaction’ of the WIG.

Element Name	Instructions / Rules	Error code
MessageType	Mandatory, value must be "bnLodgeApplication"	00002
MessageVersion	Mandatory, value must be 2	00004
senderType	Mandatory, value must be "REGA"	00005
senderId	The identifier assigned by ASIC on registration	00005
transactionReferenceNumber	<p>The Transaction Reference Number advised by the software client. Must be included for applications prepaid using Initiate Payment message.</p> <p>Mandatory, value must be unique for your transactions</p> <p>Application transaction must be in progress</p>	<p>00116</p> <p>00125</p> <p>00114</p>
processMode	<p>Indicates desired processing option. Valid values:</p> <ul style="list-style-type: none"> - PROCESS – application is to be submitted for processing. 	00144

Business Document Header

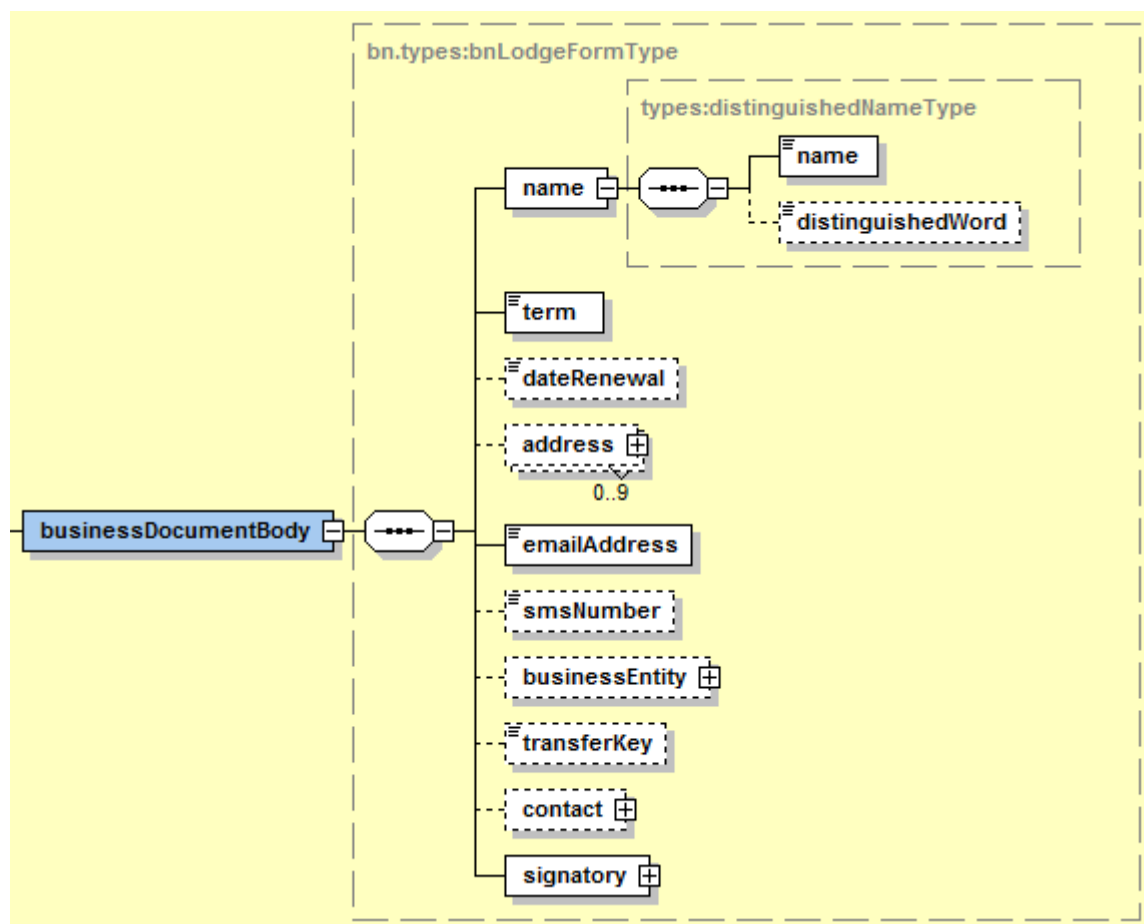

Business Entity

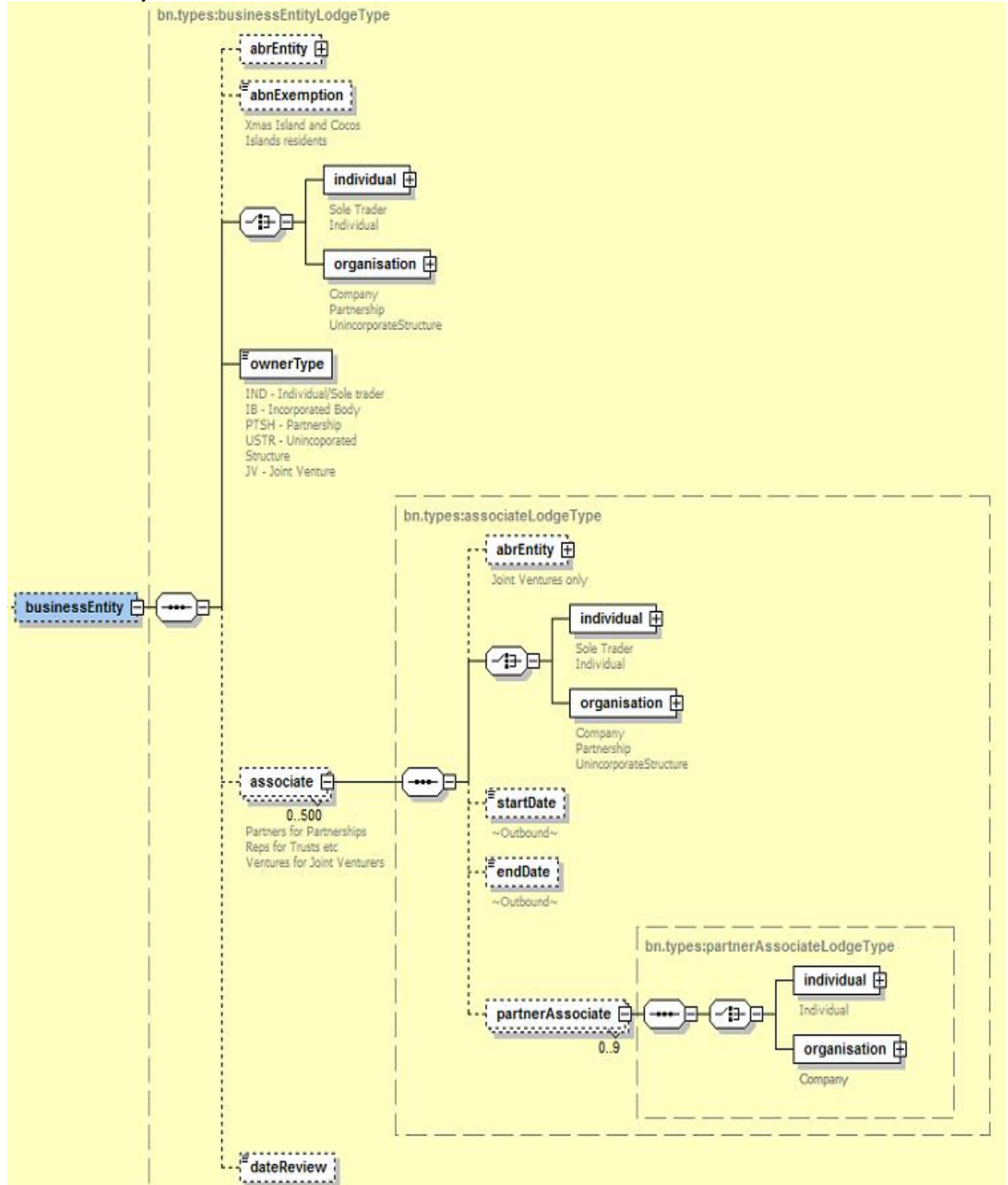

ABR Entity, Individual and organisation Details

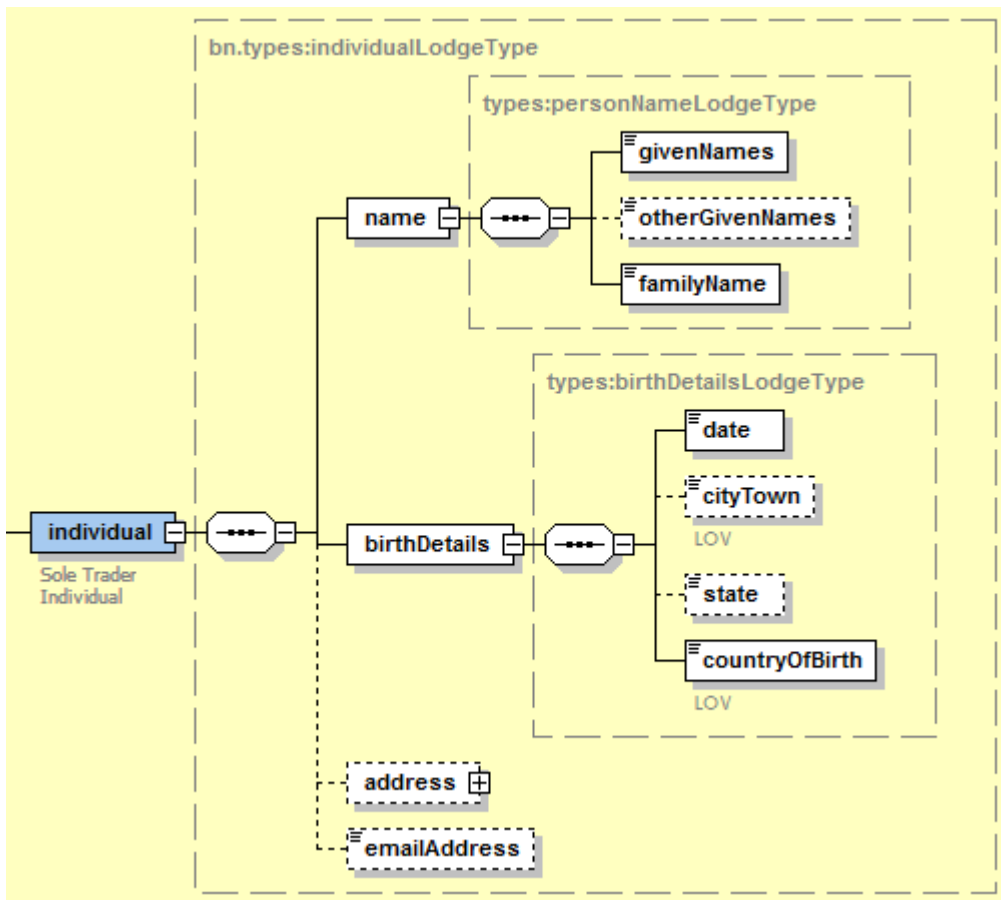
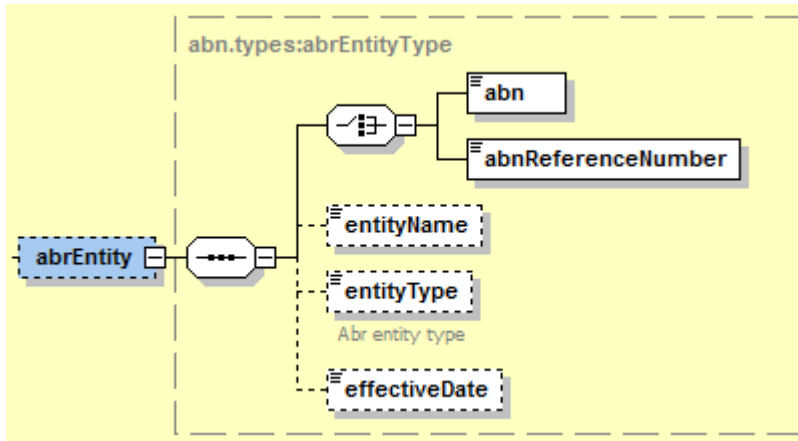

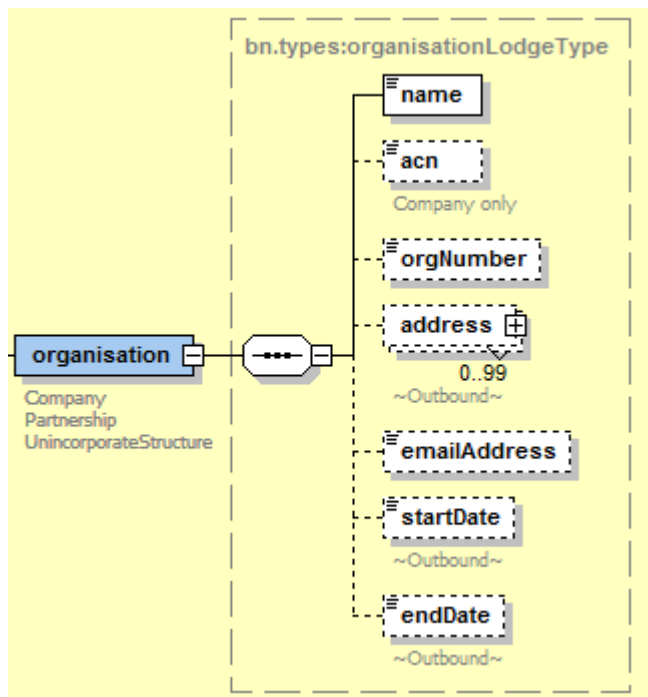

Address Type

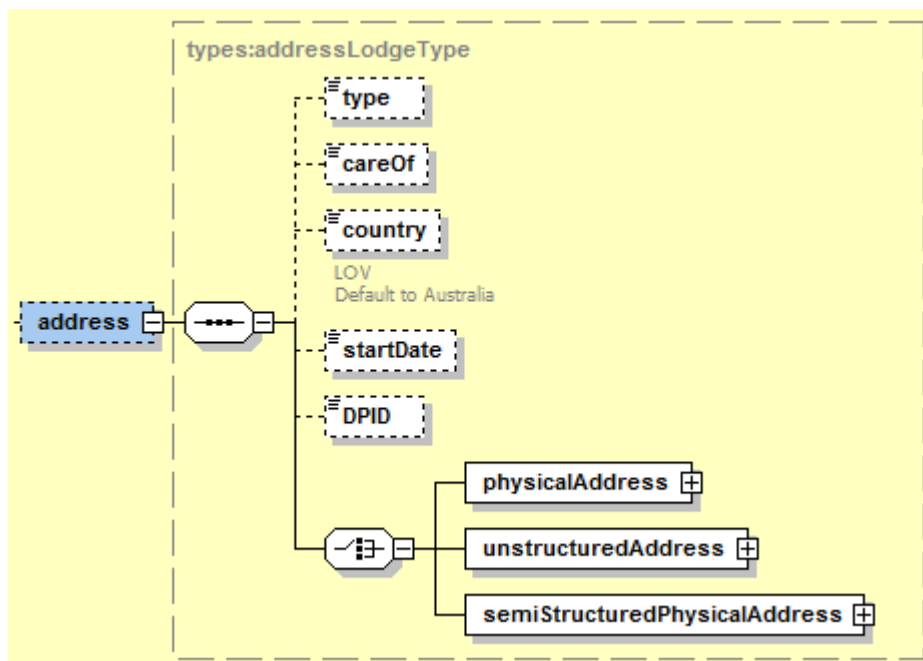

Contact and Signatory Details

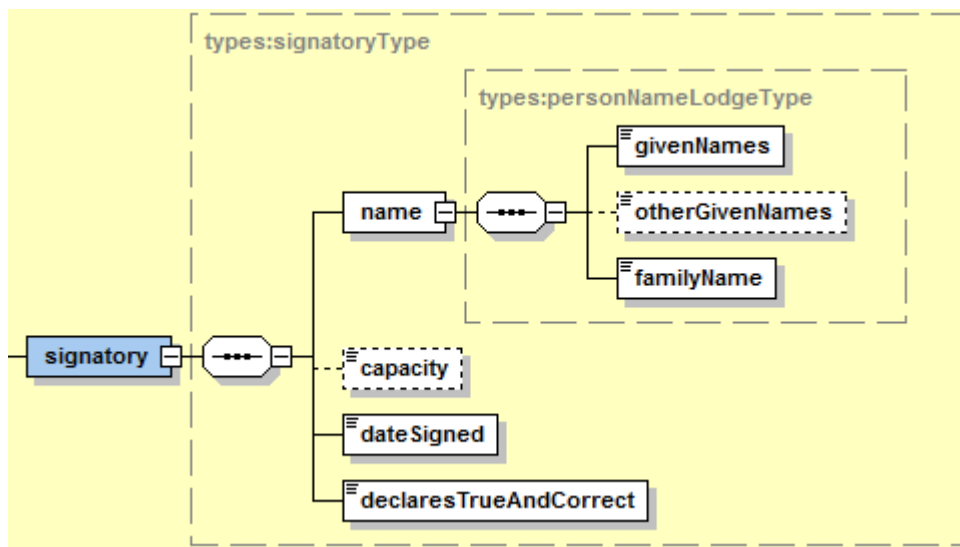
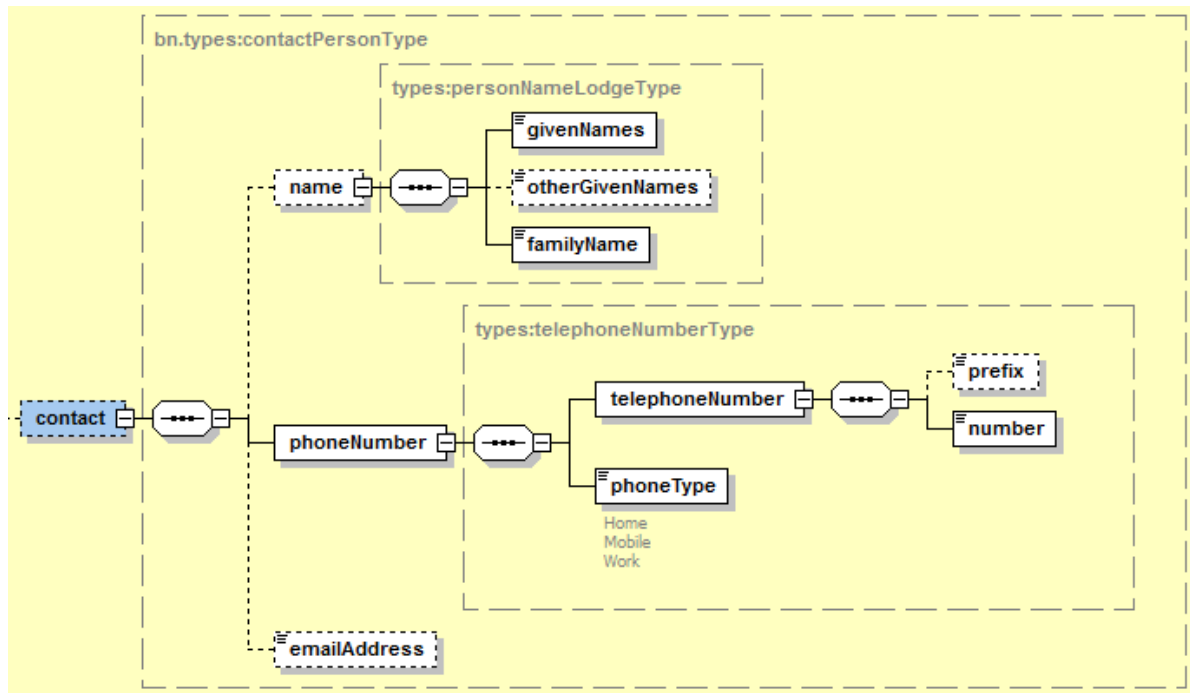

Message Content Table

Seq. No	XML Element	Type	Description	Business Rules/Instructions
1	name	Complex content	Contains the proposed business name	Mandatory
1.1	name	types:nniNameType	The proposed business name	<ol style="list-style-type: none"> 1. Mandatory 2. It can contain up to valid 200 chars, including spaces. 3. Must contain valid characters: A to Z 0 to 9 ! @ # \$ % ^ & * " () ? ; : = _ - / \ . , ' { } 4. The proposed name in the lodgement must match the proposed name in the initiate payment request
1.2	distinguishedWord	types:distinguishedWordType	Not relevant to this message	<ol style="list-style-type: none"> 1. Not required
2	term	termType	The initial period of registration for the new business name that may be for one year or three years.	<ol style="list-style-type: none"> 1. Mandatory 2. Valid values: 1 or 3 3. Term value must match the business name term in the initiate payment request.
3	dateRenewal	xs:date	<p>Renewal date, if the applicant/holder wishes to align the renewal date with a review/renewal date for another company/business name owned by same holder with the same ABN.</p> <p>For more information on renewal date alignment please refer to Appendix B.</p>	<ol style="list-style-type: none"> 1. Optional, only when the lodger want to align the renewal date of the new business name with an existing company or other business name 2. If the registration period would otherwise have been 1 year - of no more than 18 months 3. If the registration period would otherwise have been 3 years—of no more than 3 years and 6 months

Seq. No	XML Element	Type	Description	Business Rules/Instructions
4	address	Complex content	Addresses for the business such as: <ol style="list-style-type: none"> the principal place of business address for the new business to be registered address for the service of documents 	<ol style="list-style-type: none"> Must be a valid address Must provide the following two mandatory addresses(see valid codes below): <ul style="list-style-type: none"> the principal place of business address for the new business to be registered the service of notice address Must be specified either as a physicalAddress (seq 4.5) or as a semiStructuredPhysicalAddress (seq 4.6)
4.1	type	types:addressType	Type of address	Valid values are: GD - for the address of the principal place of business GE – for the service of documents address
4.2	careOf	xs:string	Care Of	Optional
4.3	country	xs:string	Country name as per Appendix C	Optional. Value must be "Australia" in this context.
4.4	startDate	xs:date	The date from which the address is effective	Optional
4.5	physicalAddress	Complex content	Contains the data elements required for the Australian addresses	<ol style="list-style-type: none"> Mandatory Both addresses must be Australian addresses
4.5.1	floorNumber	xs:string	The level of the building	Optional
4.5.2	propertyName	xs:string	The name of the property	Optional
4.5.3	unitOrOfficeNumber	xs:string	The unit number	Optional
4.5.4	streetNumber	xs:string	The street number	Optional
4.5.5	streetName	xs:string	Street name	Optional
4.5.6	streetType	xs:string	Street type	Must be a valid type - the list of valid values is available in Appendix C – LIST OF Values
4.5.7	postalDeliveryType	xs:string	The postal delivey type (e.g. PO Box, Locked Bag, etc)	1. Optional

Seq. No	XML Element	Type	Description	Business Rules/Instructions
				2. Must be a valid type – the list of values is available in 3. Appendix C – LIST OF Values 4. Can only be used for address type GE (address for service)
4.5.8	postalDeliveryNumber	xs:string	The number associated with the postal delivery type	5. Defined in schema as Optional. 6. This element is mandatory for only certain postalDeliveryType enumerations 7. Refer to Appendix C for list of postalDeliveryTypes that require a postalDeliveryNumber
4.5.9	locality	xs:string	Locality or suburb	1. Mandatory 2. Must be formatted in title case (ex: North Sydney)
4.5.10	state	types:stateTerritoryCodeType	Australian state code with	Mandatory, valid values are: ACT; NSW; NT; QLD; SA; TAS; VIC; WA
4.5.11	postCode	xs:string	The post code	Mandatory
4.6	semiStructuredPhysicalAddress	complexType	Contains unstructured address	Mandatory (if address data provided in a semi-structured format)
4.6.1	addressLine1	xs:string	The first line of an address block.	Mandatory
4.6.2	addressLine2	xs:string	The second line of an address block.	Optional
4.6.3	locality	xs:string	Locality or suburb	Mandatory
4.6.4	state	types:stateTerritoryCodeType	Australian state code with	Valid values: ACT; NSW; NT; QLD; SA; TAS; VIC; WA
4.6.5	postCode	xs:string	A post code issued by the post office	Mandatory
4.7	unstructuredAddress	Complex content	Used for the provision of foreign addresses.	Not applicable for principal place of business and the service of documents addresses as these must be Australian addresses.

Seq. No	XML Element	Type	Description	Business Rules/Instructions
4.7.1	addressLine1	xs:string	Address line 1 - may contain the details of the address such as street number, building name	Not required
4.7.2	addressLine2	xs:string	Address line 2 – it may contains the details of the address such as street name, suburb, postcode.	Not required
4.7.3	addressLine3	xs:string	Address line 3	Not required
4.7.4	addressLine4	xs:string	Address line 4	Not required
5	emailAddress	types:emailType	The email address for the business that can be used for future correspondence related to the business name. Email address is private data and it is not publically available.	Mandatory – the email address will be used as a preferred address for all correspondence and it is collected under ASIC's Electronic Lodgement Protocol. For example the Record of Registration, ASIC Key and Invoice/Payment Advice for the new business name as well as notices under the BNR Act
6	smsNumber	xs:string	SMS number SMS number is private data and it is not publically available.	Optional. By providing a mobile number consent is given to using the number to deliver SMS messages such as alerts, reminders
7	businessEntity	complexType	Container for information related to the entity applying for the business name (business name holder)	Mandatory. Business name registrations must specify ABN, ABN Reference Number or ABN Exemption. All business name registrations paid under the same initiate payment request must all specify the same ABN, ABN Reference Number or ABN Exemption.
7.1	abrEntity	Complex content	Container for ABR information regarding the entity applying for the business name (i.e. the holder of the business name)	Mandatory for all entity types except the Joint ventures(not registered for ABN) and the residents of Christmas Island and Cocos Island

Seq. No	XML Element	Type	Description	Business Rules/Instructions
7.1.1	abn	abnType	Australian Business Number	<ol style="list-style-type: none"> 1. One ABR identifier – ABN or ABN Reference Number must be provided. 2. Must be a valid value in ABR register. 3. The status of the entity owning the ABN in ABR register must be 'current'. 4. The provided ABN must match the nominated ABN in the initiate payment request. 5. Where the initiate payment includes a company registration, the ABN provided must be the related company ABN.
7.1.2	abnReferenceNumber	xs:positiveInteger	ABR Reference Number provided when an application for ABN is lodged with ABR, if the ABN is not granted immediately	Optional - ABN Reference Number must be provided if ABN is not provided The ABN reference must match the nominated ABN reference in the initiate payment request.
7.1.3	entityName	orgNameType	Name of the entity applying for a business name	<ol style="list-style-type: none"> 1. Mandatory. 2. Must match the name registered in ABR for entity types except the individuals.
7.1.4	entityType	xs:string	Entity type as recorded in ABR register for the entity applying for the business name.	Valid list of types as per mapping provided in Appendix A
7.1.5	effectiveDate	xs:date	The date recorded in ABR as effective date for the ABN	Must match ABR records
7.2	abnExemption	types:trueType	Indicates that the holder is exempted from holding an ABN under one of the two scenarios: <ul style="list-style-type: none"> • joint venture or • Christmas Island and Cocos islands entities 	Valid value is 'true' if holder is exempted from holding an ABN (i.e. the entities type Joint venture or the entities from Cocos Islands and Christmas Island The ABN exemption value must match the nominated ABN exemption value in the initiate payment request.

Seq. No	XML Element	Type	Description	Business Rules/Instructions
7.3	individual	Complex content	Container for information required for the holder applying for the business name when the legal entity is 'Individual' (sole trader)	Conditional as follows: <ul style="list-style-type: none"> Mandatory when the holder type is individual Not required for all other entity type (e.g. companies, partnerships, JV, trusts)
7.3.1	name	types:personNameType	Container for the name of the individual (sole trader) applying for the business name	Mandatory
7.3.1.1	givenNames	xs:string	Given name of the individual	Mandatory
7.3.1.2	otherGivenNames	xs:string	Other given names	Optional
7.3.1.3	familyName	xs:string	Family name of the individual	Mandatory
7.3.2	birthDetails	Complex content	Container for the birth details of the individual applying for the business name Birth details is private data and it is not publically available.	Mandatory
7.3.2.1	date	xs:date	Date of birth	1. Mandatory 2. Must be a date before current date
7.3.2.2	cityTown	xs:string	Locality/city/town of birth	1. Optional 2. Must be formatted in title case (ex: North Sydney)
7.3.2.3	state	xs:string	State code for the state of birth, if in Australia.	1. Optional. 2. Valid values: ACT; NSW, NT; QLD; SA; TAS; VIC; WA
7.3.2.5	countryOfBirth	xs:string	Country name for country of birth	Mandatory
7.3.3	address	Complex content	The physical address of the individual who is the holder of the business name	Mandatory
7.3.3.1	type	types:addressType	Type of address	Must be " GC " (meaning Business Name Individual Residential Address)

Seq. No	XML Element	Type	Description	Business Rules/Instructions
7.3.3.2	careOf	xs:string	To be used for intermediary details that may be added to mail addresses as 'care of' (c/-)	1. Not required
7.3.3.3	country	xs:string	Country name as per Appendix C	Optional. If not provided it will be defaulted to "Australia"
7.3.3.4	startDate	xs:date	The date from which the address is effective	Optional
7.3.3.5	physicalAddress	Complex content	Contains the data elements required for the Australian addresses	Conditional – must be used if the residential address is an Australian address
7.3.3.5.1	floorNumber	xs:string	The level of the building	Optional
7.3.3.5.2	propertyName	xs:string	The name of the property	Optional
7.3.3.5.3	unitOrOfficeNumber	xs:string	The unit number	Optional
7.3.3.5.4	streetNumber	xs:string	The street number	Optional
7.3.3.5.5	streetName	xs:string	Street name	Optional
7.3.3.5.6	streetType	xs:string	Street type	Must be a valid type - the list of valid values is available in Appendix C – LIST OF Values
7.3.3.5.7	locality	xs:string	Locality or suburb	Mandatory Must be formatted in title case (ex: North Sydney)
7.3.3.5.8	state	types:stateTerritoryCodeType	Australian state code	Mandatory, valid values are: ACT; NSW; NT; QLD; SA; TAS; VIC; WA
7.3.3.5.9	postCode	xs:string	Australian postcode	Mandatory
7.3.3.6	semiStructuredPhysicalAddress	complexType	Contains unstructured address	Mandatory (if address data provided in a semi-structured format)
7.3.3.6.1	addressLine1	xs:string	The first line of an address block.	Mandatory
7.3.3.6.2	addressLine2	xs:string	The second line of an address block.	Optional
7.3.3.6.3	locality	xs:string	Locality or suburb	Mandatory

Seq. No	XML Element	Type	Description	Business Rules/Instructions
7.3.3.6.4	state	types:stateTerritoryCodeType	Australian state code with	Valid values: ACT; NSW; NT; QLD; SA; TAS; VIC; WA
7.3.3.6.5	postCode	xs:string	A post code issued by the post office	Mandatory
7.3.3.7	unstructuredAddress	Complex content	Container for the foreign address	Conditional – must be used if the residential address is an foreign address
7.3.3.7.1	addressLine1	xs:string	Mandatory - contains the details of the address such as street number, building name	Mandatory
7.3.3.7.2	addressLine2	xs:string	Mandatory - contains the details of the address such as street name, suburb, postcode.	Mandatory
7.3.3.7.3	addressLine3	xs:string	Optional	Optional
7.3.3.7.4	addressLine4	xs:string	Optional	Optional
7.3.4	emailAddress	types:emailType	The email address of the individual holder of the business name. Email address is private data and it is not publically available.	Optional
7.4	organisation	Complex content	Container for information required for the holder applying for the business name when the legal entity is any of the types except 'Individual' (sole trader)	Conditional as follows: <ul style="list-style-type: none"> • Mandatory for all holder types except individual (e.g. companies, partnerships, JV, trusts) • Not required for individuals holders
7.4.1	name	nniNameType	The legal name of the company applying for the business name	1.Mandatory. 2.Must match the name as per ASIC records.

Seq. No	XML Element	Type	Description	Business Rules/Instructions
7.4.2	acn	nniNumberType	The ACN of the company applying for the business name	1. Conditional as follows: <ul style="list-style-type: none"> • Mandatory for incorporated bodies • Not required for any other type of holder. 2. Must comply with the ACN algorithm. 3. Must belong to company that exists in ASIC register. 4. Must belong to a company with status 'registered in ASIC register'
7.4.3	orgNumber	xs:string	Not relevant to this message	1. Not required
7.4.4	address	complexType	Not relevant to this message	1. Not required
7.4.5	emailAddress	types:emailType	The email address of the entity that is company/registered body that applies for the business name	1. Optional
7.4.6	startDate	xs:date	Not relevant to this message	1. Not required
7.4.7	endDate	xs:date	Not relevant to this message	1. Not required
7.5	ownerType	xs:string	Indicates the type of holder, according with ASIC types.	Valid values are: IND – for individual holder (sole trader) IB – for incorporated bodies (e.g. private or public companies) PTSH – for partnerships USTR – for unincorporated entities (e.g. trusts, associations, coops) JV – for the joint ventures
7.6	associate	Complex content	Contains the information related to each person or company that represents the business name holder. Note: the term 'associate' does not have any legal meaning (it represents a	Conditional as follows: 1) Mandatory if the holder is an unincorporated structure, a partnership or a joint venture. IF the entity type = PTSH (partnership) or JV (Joint venture): It must contain the

Seq. No	XML Element	Type	Description	Business Rules/Instructions
			<p>container of data) and it should not be used on the UI.</p> <p>We suggest the user interfaces to display the correct description according with the holder type. For example: partners of the partnership, joint venture partners in a joint venture, trustees in a trust.</p>	<p>partner's details of the partnership or in a joint venture</p> <p>IF the entity type = USTR (unincorporated entities): It must contain the organisation representatives details for the entity (for example the trustees)</p> <p>2) Not required if holder 'Individual' or 'incorporated body' (e.g. companies)</p>
7.6.1	abrEntity	Complex content	Container for ABR information for the joint venture partner or other entity type	<p>Conditional as follows:</p> <ul style="list-style-type: none"> • Mandatory if the entity is a Joint venture • Optional for all entity types except the Joint venture type
7.6.1.1	abn	abnType	ABN	Mandatory
7.6.1.2	abnReferenceNumber	xs:positiveInteger	ABR Reference Number provided when an application for ABN is lodged with ABR, if the ABN is not granted straight away	Not required
7.6.1.3	entityName	orgNameType	Not relevant to this message	Not required
7.6.1.4	entityType	xs:string	Not relevant to this message	Not required
7.6.1.5	effectiveDate	xs:date	Not relevant to this message	Not required
7.6.2	individual	Complex content	Contains information related to the persons that represent the holder of the business name (e.g. partners, individual trustees, individuals partners in a Joint venture)	<p>Conditional as follows:</p> <ul style="list-style-type: none"> • Mandatory if the partner/trustee is a person (e.g. individual partner, individual trustee, individual Joint venturer.) • Not required if the partner/trustee is an organisation (either incorporated or unincorporated)

Seq. No	XML Element	Type	Description	Business Rules/Instructions
7.6.2.1	name	types:personNameType	Container for the name of the person representing the business name holder	Mandatory
7.6.2.1.1	givenNames	xs:string	Given name of the individual	Mandatory
7.6.2.1.2	otherGivenNames	xs:string	Other given names	Optional
7.6.2.1.3	familyName	xs:string	Family name of the individual	Mandatory
7.6.2.2	birthDetails	Complex content	Birth details for the person representing the business name holder. Birth details are private data and it is not publically available.	Mandatory
7.6.2.2.1	date	xs:date	Date of birth	1. Mandatory 2. Must be a date before current date
7.6.2.2.2	cityTown	xs:string	Locality/city/town of birth	1. Optional 2. Must be formatted in title case (ex: North Sydney)
7.6.2.2.3	state	xs:string	State code for the state of birth, if in Australia.	1. Optional. 2. Valid values: ACT; NSW, NT; QLD; SA; TAS; VIC; WA
7.6.2.2.4	countryOfBirth	xs:string	Country name for country of birth	Mandatory
7.6.2.3	address	Complex content	Residential address of the person representing the business name holder (e.g. partner, trustee, etc)	Mandatory
7.6.2.3.1	type	types:addressTypeType	Type of address	Value must be "GC" (meaning Residential Address)
7.6.2.3.2	careOf	xs:string	'Care of' (c/-)	Not required
7.6.2.3.3	country	xs:string	Country name as per Appendix C	Optional. If not provided it will be defaulted to "Australia"
7.6.2.3.4	startDate	xs:date	The date from which the address is effective	Optional
7.6.2.3.5	physicalAddress	Complex content	Contains the data elements required for the Australian addresses	Conditional – must be used if the residential address is an Australian address

Seq. No	XML Element	Type	Description	Business Rules/Instructions
7.6.2.3.5.1	floorNumber	xs:string	The level of the building	Optional
7.6.2.3.5.2	propertyName	xs:string	The name of the property	Optional
7.6.2.3.5.3	unitOrOfficeNumber	xs:string	The unit number	Optional
7.6.2.3.5.3	streetNumber	xs:string	The street number	Optional
7.6.2.3.5.4	streetName	xs:string	Street name	Optional
7.6.2.3.5.5	streetType	xs:string	Street type	Must be a valid type - the list of valid values is available in Appendix C – LIST OF Values
7.6.2.3.5.6	locality	xs:string	Locality or suburb	1. Mandatory 2. Must be formatted in title case (ex: North Sydney)
7.6.2.3.5.7	state	types:stateTerritoryCodeType	Australian state code	Mandatory, valid values are: ACT; NSW; NT; QLD; SA; TAS; VIC; WA
7.6.2.3.5.8	postCode	xs:string	Australian postcode	Mandatory
7.6.2.3.6	semiStructuredPhysicalAddress	complexType	Contains unstructured address	Mandatory (if address data provided in a semi-structured format)
7.6.2.3.6.1	addressLine1	xs:string	The first line of an address block.	Mandatory
7.6.2.3.6.2	addressLine2	xs:string	The second line of an address block.	Optional
7.6.2.3.6.3	locality	xs:string	Locality or suburb	Mandatory
7.6.2.3.6.4	state	types:stateTerritoryCodeType	Australian state code with	Valid values: ACT; NSW; NT; QLD; SA; TAS; VIC; WA
7.6.2.3.6.5	postCode	xs:string	A post code issued by the post office	Mandatory
7.6.2.3.7	unstructuredAddress	Complex content	Contains the foreign addresses	Conditional – must be used if the residential address is an foreign address
7.6.2.3.7.1	addressLine1	xs:string	Mandatory - contains the details of the address such as street number, building name	Mandatory

Seq. No	XML Element	Type	Description	Business Rules/Instructions
7.6.2.3.7.2	addressLine2	xs:string	Mandatory - contains the details of the address such as street name, suburb, postcode.	Mandatory
7.6.2.3.7.3	addressLine3	xs:string	Address line 3	Optional
7.6.2.3.7.4	addressLine4	xs:string	Address line 4	Optional
7.6.2.4	emailAddress		Email address for the person (e.g. partner, trustee, etc) Email address is private data and it is not publically available.	Optional
7.6.3	organisation	Complex content	Contains the information related to the organisations (e.g. partner, trustee) representing the business name holder	Conditional as follows: <ul style="list-style-type: none"> • Mandatory if the entity is a an organisation (either incorporated or unincorporated) • Not required if person (e.g. individual partner, individual trustee, individual Joint venturer.)
7.6.3.1	name	types:nniNameType	The legal name of the incorporated entity	1.Mandatory. 2.Must match the name as per ASIC records.
7.6.3.2	acn	types:nniNumberType	The ACN of the company	1.Mandatory. 2.Must comply with the ACN algorithm. 3.Must belong to company that exists in ASIC register. 4.Must belong to a company with status 'registered'.
7.6.3.3	orgNumber	xs:string	Not relevant to this message	1. Not required
7.6.3.4	address	complexType	Not relevant to this message	1. Not required
7.6.3.5	emailAddress	types:emailType	Email address of the company Email address is private data and it is not publically available.	Optional
7.6.3.6	startDate	xs:date	Not relevant to this message	1. Not required

Seq. No	XML Element	Type	Description	Business Rules/Instructions
7.6.3.7	endDate	xs:date	Not relevant to this message	1. Not required
7.6.4	startDate	xs:date	Not relevant to this message	1. Not required
7.6.5	endDate	xs:date	Not relevant to this message	1. Not required
7.6.6	partnerAssociate	Complex content	<p>Contains information related to the individuals or companies that are the organisation representatives of a partner of joint venture. It applies only to partners or joint venture partners that are 'unincorporated' organisations.</p> <p>Note: the term 'partnerAssociate' does not have any legal meaning (it represents a container of data) and it should not be used on the UI. We suggest the user interfaces to display the correct description (for example: organisation representative).</p>	<p>Conditional as follows:</p> <ul style="list-style-type: none"> • Required when business name holder a partnership/joint venture and one of the partners is an 'unincorporated' entity (e.g. a trust): It must contain details for at least one organisation representative (person or organisation) • Not required for other types of holders or for the partners/joint venture partners are either persons or incorporated entities.
7.6.6.1	individual	Complex content	Contains information related to the person who is organisation representative for a partner or joint venture partner of type 'unincorporated' (e.g. trustee of the trust)	Conditional as per above.
7.6.6.1.1	name	types:personNameType	Container for the name of the person.	Mandatory.
7.6.6.1.1.1	givenNames	xs:string	Given name of the individual	Mandatory.
7.6.6.1.1.2	otherGivenNames	xs:string	Other given names	
7.6.6.1.1.3	familyName	xs:string	Family name of the individual	Mandatory.
7.6.6.1.2	birthDetails	Complex content	The birth details for the person who is organisation representative for a partner	Mandatory

Seq. No	XML Element	Type	Description	Business Rules/Instructions
			or joint venture partner of type 'unincorporated' (e.g. trustee of the trust). Birth details is private data and it is not publically available.	
7.6.6.1.2.1	date	xs:date	Date of birth	Mandatory
7.6.6.1.2.2	cityTown	xs:string	Locality/city/town of birth	1. Optional 2. Must be formatted in title case (ex: North Sydney)
7.6.6.1.2.3	state	xs:string	State code for the state of birth, if in Australia.	Optional
7.6.6.1.2.4	countryOfBirth	xs:string	Country name for country of birth	Optional
7.6.6.1.3	address	Complex content	Residential address for the person who is organisation representative for a joint venture partner type 'unincorporated' structure (e.g. trustee of the trust)	Mandatory
7.6.6.1.3.1	type	types:addressType	Type of address	Must be type = "GC" (meaning Individual Residential Address)
7.6.6.1.3.2	careOf	xs:string	'care of' (c/-)	1.Not required
7.6.6.1.3.3	country	xs:string	Country name as per Appendix C	Optional. If not provided it will be defaulted to "Australia"
7.6.8.1.4.4	startDate	xs:date	The date from which the address is effective	1.Optional
7.6.6.1.3.5	physicalAddress	Complex content	Contains the data elements required for the Australian addresses	Conditional – must be used if the residential address is an Australian address
7.6.6.1.3.5.1	floorNumber	xs:string	The level of the building	Optional
7.6.6.1.3.5.2	propertyName	xs:string	The name of the property	Optional
7.6.6.1.3.5.3	unitOrOfficeNumber	xs:string	The unit number	Optional
7.6.6.1.3.5.4	streetNumber	xs:string	The street number	Optional
7.6.6.1.3.5.5	streetName	xs:string	Street name	Optional

Seq. No	XML Element	Type	Description	Business Rules/Instructions
7.6.6.1.3.5.6	streetType	xs:string	Street type	Must be a valid type - the list of valid values is available in Appendix C – LIST OF Values
7.6.6.1.3.5.7	locality	xs:string	Locality or suburb	Mandatory Must be formatted in title case (ex: North Sydney)
7.6.6.1.3.5.8	state	types:stateTerritoryCodeType	Australian state code with valid values: ACT; NSW; NT; QLD; SA; TAS; VIC; WA	Mandatory, valid values are: ACT; NSW; NT; QLD; SA; TAS; VIC; WA
7.6.6.1.3.5.9	postCode	xs:string	Australian postcode	Mandatory
7.6.6.1.3.6	semiStructuredPhysicalAddress	complexType	Contains unstructured address	Mandatory (if address data provided in a semi-structured format)
7.6.6.1.3.6.1	addressLine1	xs:string	The first line of an address block.	Mandatory
7.6.6.1.3.6.2	addressLine2	xs:string	The second line of an address block.	Optional
7.6.6.1.3.6.3	locality	xs:string	Locality or suburb	Mandatory
7.6.6.1.3.6.4	state	types:stateTerritoryCodeType	Australian state code with	Valid values: ACT; NSW; NT; QLD; SA; TAS; VIC; WA
7.6.6.1.3.6.4	postCode	xs:string	A post code issued by the post office	Mandatory
7.6.6.1.3.7	unstructuredAddress	Complex content	Contains the foreign addresses	Conditional – must be used if the residential address is an foreign address
7.6.6.1.3.7.1	addressLine1	xs:string	Mandatory - contains the details of the address such as street number, building name	Mandatory
7.6.6.1.3.7.2	addressLine2	xs:string	Mandatory - contains the details of the address such as street name, suburb, postcode.	Mandatory
7.6.6.1.3.7.3	addressLine3	xs:string	Address line 3	Optional
7.6.6.1.3.7.4	addressLine4	xs:string	Address line 4	Optional
7.6.6.1.4	emailAddress	xs:string	Email address of the person who is the organisation representative for a joint	Optional

Seq. No	XML Element	Type	Description	Business Rules/Instructions
			venture partner type 'unincorporated' structure (e.g. trustee of the trust). Email address is private data and it is not publically available.	
7.6.6.2	organisation	Complex content	Contains information related to the company/body corporate that is organisation representative for a partner or joint venture partner type 'unincorporated' structure (e.g. corporate trustee of the trust)	Conditional as per rules for 'partnerAssociate'
7.6.6.2.1	name	types:nniNameType	The legal name of the company that is legal representative for a partner/JV partner type 'unincorporated' structure (e.g. corporate trustee of the trust)	Mandatory.
7.6.6.2.2	acn	types:nniNumberType	The ACN of the company that is legal representative for a partner/JV partner type 'unincorporated' structure (e.g. corporate trustee of the trust)	<ol style="list-style-type: none"> 1. Mandatory. 2. Must comply with the ACN algorithm. 3. Must belong to company that exists in ASIC register. 4. Must belong to a company with status 'registered'.
7.6.6.2.3	address	complexType	Not relevant to this message	1. Not required
7.6.6.2.4	emailAddress	types:emailType	The email address for the company that is organisation representative for a partner/joint venture partner type 'unincorporated' structure (e.g. corporate trustee of the trust). Email address is private data and it is not publically available.	Optional
7.6.6.2.5	startDate	xs:date	Not relevant to this message	1. Not required
7.6.6.2.6	endDate	xs:date	Not relevant to this message	1. Not required

Seq. No	XML Element	Type	Description	Business Rules/Instructions
7.7	dateReview	xs:date	Not relevant to this message	1.Not required
8	transferKey	types:keyType	Identifier issued by ASIC for the business names that have been cancelled with the intent to transfer them to another holder	Must be a valid transfer key issued by ASIC Maximum length 23 characters. The format can be one of the below: <ul style="list-style-type: none"> • n-nnnnnnnnnnnn (or) • nn-nnnnnnnnnnnn e.g. 1-12958509282
9	contact	Complex content	Not required	1.Not required
10	signatory	Complex content	To be used for the information related with the person signing for the application	Mandatory
10.1	name	Complex content	Name of the person 'signing' meaning that has authorised the lodgement	Mandatory
10.1.1	givenNames	xs:string	Given name of the person	Mandatory
10.1.2	otherGivenNames	xs:string	Other given names	Optional
10.1.3	familyName	xs:string	Family name of the individual	Mandatory.
10.2	capacity	xs:string	To be used for the capacity (position) of the person signing the declaration	1.Not required
10.3	dateSigned	xs:date	Date of declaration	Use 'current' date Must not be later than lodgement date
10.4	declaresTrueAndCorrect	types:trueType	Indicates that user has read and agreed with the statements presented in the 'Declaration" and 'Authority' sections (refer to section 0 Signatory)	Must be 'true' or '1'

9.6.4. bnLodgeApplication Reply Message

Business Document Header

The WIG provides the standard specification of the Business Document Header. The following table specifies the message level specific data element values or any variations to the WIG.

Element Name	Instructions / Rules
MessageType	1. Mandatory, value is "bnLodgeApplication"
Attachments -> Attachment	1. Provided when the lodgement is successful 2. Contains the URL links for the PDF files produced by ASIC as a proof of lodgement. The requestor should be able to print/save the document as future reference.
documentType	1. Mandatory.
URL	1. URL link to the PDF file produced by ASIC as a proof of lodgement
asicTransactionNumber	1. Mandatory – transaction unique identifier assigned by ASIC for this transaction

Business Document Body

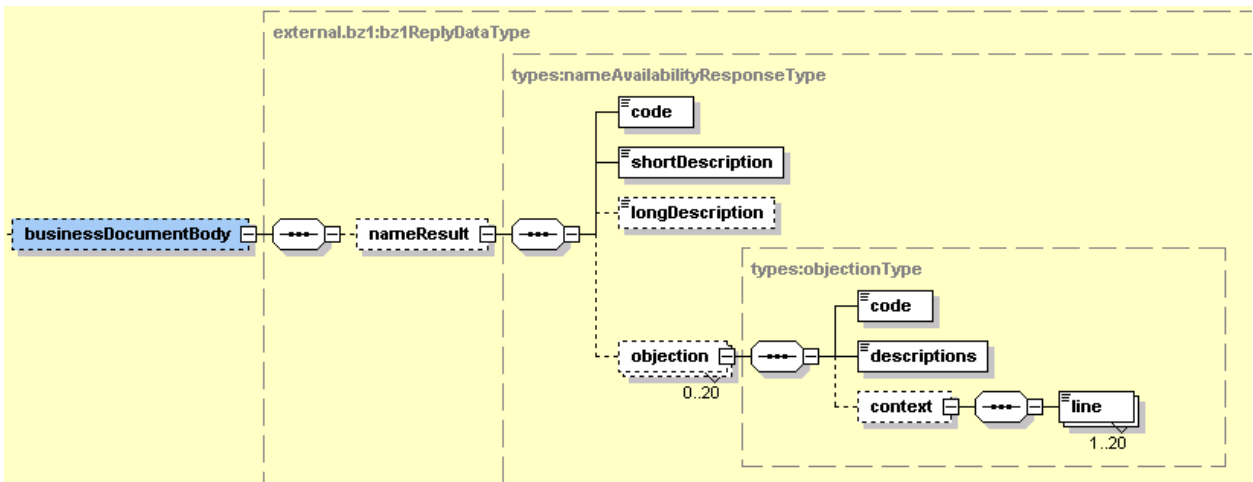

Message Content Table

Seq. No	XML Element	Type	Description
1	nameResult	Complex content	Indicates the result of the name assessment for the proposed business upon submitting the application. This validation is same with the validation done using the queryNameAvailability service.
1.1	code	xs:string	Will return one of the following valid values :

Seq. No	XML Element	Type	Description
			<p>Available –the name is available to be used as a business name</p> <p>Unavailable –the name can't be used and the user should propose another name</p> <p>SubjectToNamesDetermination –the name is referred to ASIC staff for manual determination</p> <p>Some business names will require ministerial consent to have. The names that require ministerial consent will be subject to name determination. If the customer has consent has to use the name, they must supply evidence to ASIC. An attachment needs to be emailed to the following mailbox: Production mailbox – BN.Names.Determination@asic.gov.au Test mailbox – sbrp.test@asic.gov.au</p> <p>UnderTransfer –the name has been previously cancelled with the intention to transfer to another holder</p> <p>Identical – meaning the name is identical to another name and it may be rejected or referred to manual determination</p>
1.2	shortDescription	xs:string	A short text description associated with the code (as listed above) and it provides the result of the name availability check done as part of the validations for the application being submitted
1.3	longDescription	xs:string	A long text description associated with the codes (as listed above) and it provides the result of the name availability check done as part of the validations for the application being submitted
1.4	objections	Complex content	Returned only when the proposed name is unavailable or it is subject to name determination. It contains a code and a description and indicates the reason for the decision.
1.4.1	code	xs:string	The code used by ASIC for the objections. It is returned only if the name is unavailable or is referred to manual processing. Refer to appendix E for some examples of likely name availability objection codes.

Seq. No	XML Element	Type	Description
			Please note that is best to develop a generic process to display the code and description as opposed to hard coding these. ASIC may in time choose to tweak or embellish upon the objection descriptions.
1.4.2	description	xs:string	The description associated with the code of the objections.
1.4.3	context	complexType	Additional information returned when the name is identical or near identical to another existing name.
1.4.3.1	line	xs:string	Contains the ASIC internal identifier for a business name or Australian Company Number and the company name that resulted in the exact match (i.e. the existing registered name).

9.7. MESSAGE SPECIFICATION - companyLodgement

9.7.1. Business Interaction Overview

This web service allows the lodgement of an application for registration of an Australian company.

Lodgement of a company registration request will initiate a process that will result in either the registration of the requested company, or the rejection of the request.

While the aim of this is to provide rapid, automatic processing of requests, ASIC processing of a company registration request is a multi-step process that may involve manual processing. Consequently there may be a time delay between the transmission of the request and the registration (or rejection) of the company.

This service works in 2 modes:

- Validate Only – to verify that the company lodgement request is valid and can be processed if need be.
- Process – to submit the application to register a company. This is called after the payment is done and allows the client to lodge their request to register a company.

The 'process' mode of the interface will:

- a) Validate the request details against the schema;
- b) Confirm the validity of the request by looking up the Transaction Reference Number;
- c) Confirm the name availability; and
- d) Initiate the process to register the company.

The 'validate only' mode will do steps a-c and then call the backend to validate the request is able to be processed, if the need be.

If a message is sent to this interface and passes validations and name availability check, the company name is registered on the ASIC National Names Index until the company is registered or the application is rejected.

Request includes:

- The nominated Australian state or territory in which the company is taken to be registered;
- The proposed name, including legal elements, of the company. If the company does not have a proposed name, an indication that the Australian Company Number will be used as the name and the legal elements required must be provided;
- An indication whether the proposed company name is identical to a registered business name. If the name of the proposed company is identical to a registered business name details of the business name must be provided;
- The type, class and subclass of the proposed company;
- Details of the governance of the company, that is, whether the company will rely entirely on replaceable rules or if it has a constitution;
- The registered office and principal place of business addresses;
- Details of the directors and secretaries appointed to the company;

- The share structure, if any, of the company;
- Details of the members of the company.

Response includes:

- result of the name assessment performed after the lodgement of the application;
- the result for the lodgement that indicate if the application is accepted or rejected. If rejected it will also indicate the reasons.

9.7.2. HTTPS Connections & WSDL

The requestor's code must establish a HTTPS connection to the appropriate endpoint using the standard port 443.

Environment	WSDL
Production	https://www.gateway.asic.gov.au/gateway/ExternalCompanyLodgementPort?WSDL
Test	https://www.gateway.uat.asic.gov.au/gateway/ExternalCompanyLodgementPort?WSDL

9.7.3. companyLodgement Request Message

Business Document Body

The WIG provides the specification of the Business Document Header. The following table specifies the message specific data element values or any variations to the WIG.

Element Name	Instructions / Rules	Error code
MessageType	Mandatory, value must be companyLodgement	00002
MessageVersion	Mandatory , value must be 1	00004
senderType	Mandatory, value must be REGA	00005
senderId	The identifier assigned by ASIC on registration	00005
transactionReferenceNumber	<p>The Transaction Reference Number advised by the software client. Must be included for applications prepaid using Initiate Payment message.</p> <p>Mandatory, value must be unique for your transactions</p> <p>Application transaction must be in progress</p> <p>Only required for a PROCESS mode request.</p>	<p>00116</p> <p>00125</p> <p>00114</p>

Element Name	Instructions / Rules	Error code
processMode	<p>Indicates desired processing option. Valid values:</p> <ul style="list-style-type: none"> - PROCESS – application is to be submitted for processing. - VALIDATE – application is to be validated without submission for processing. - 	00144

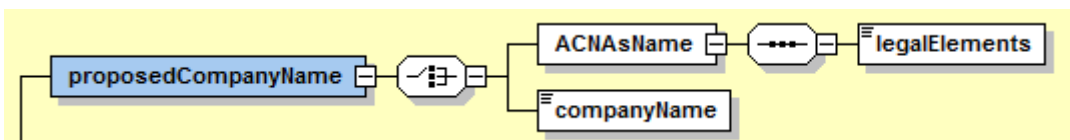
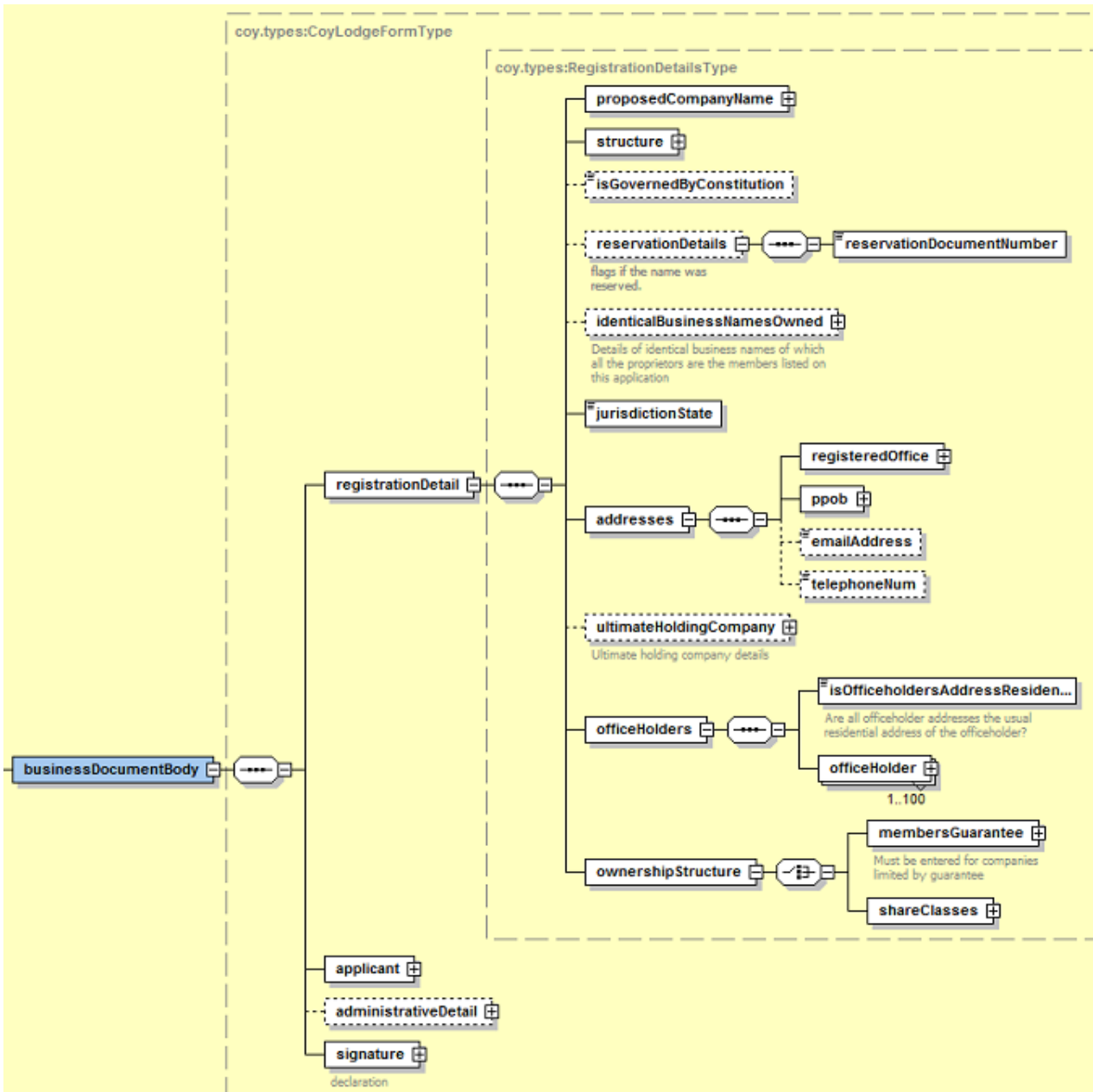

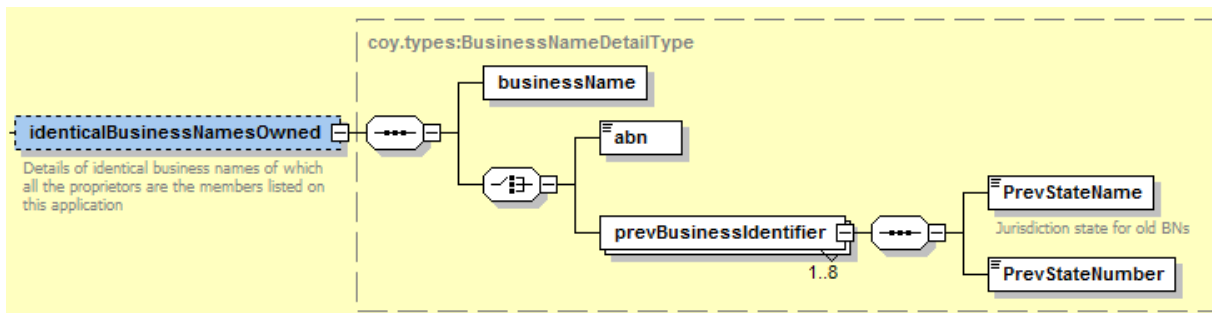
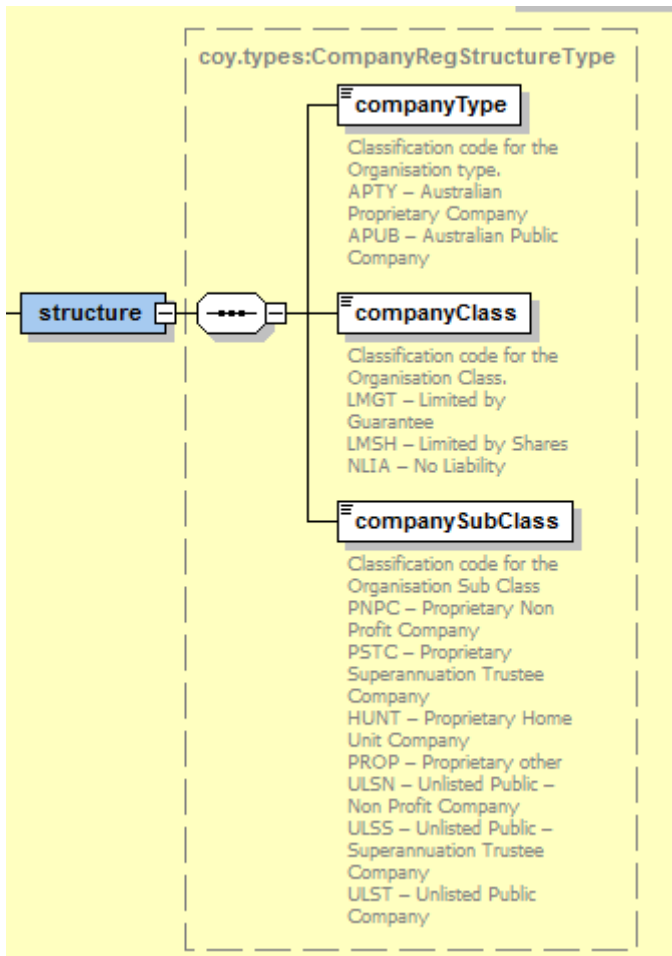

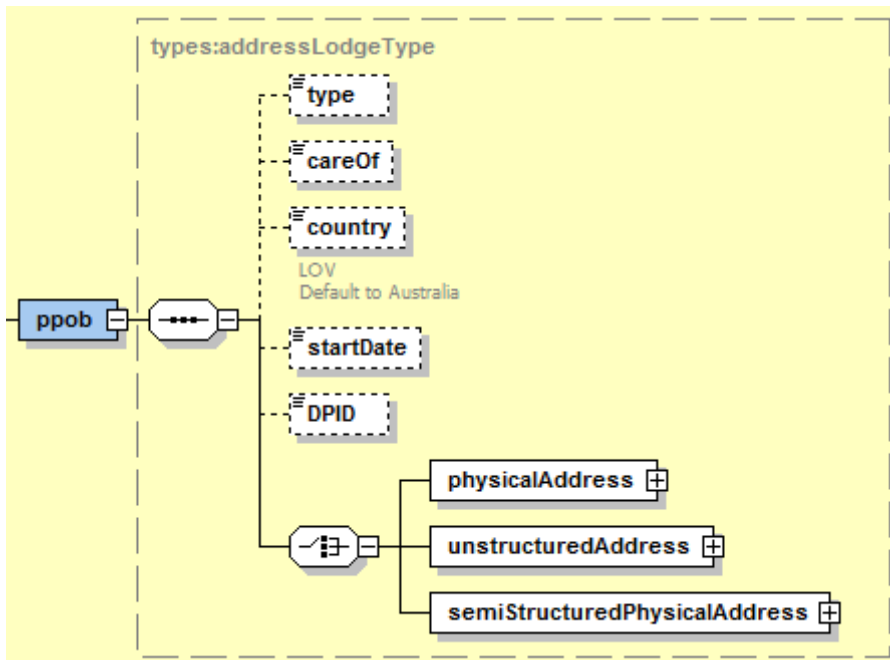
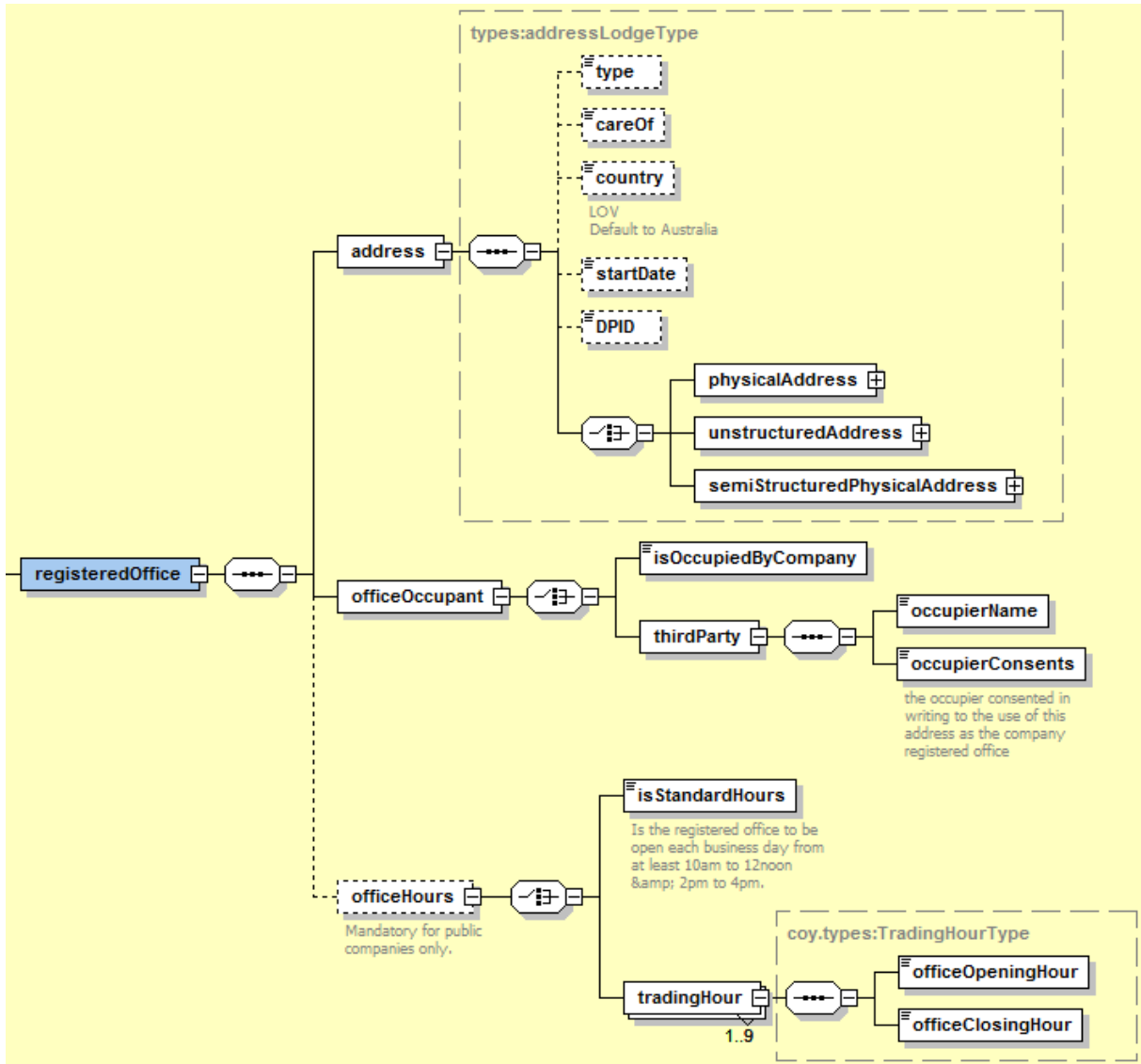

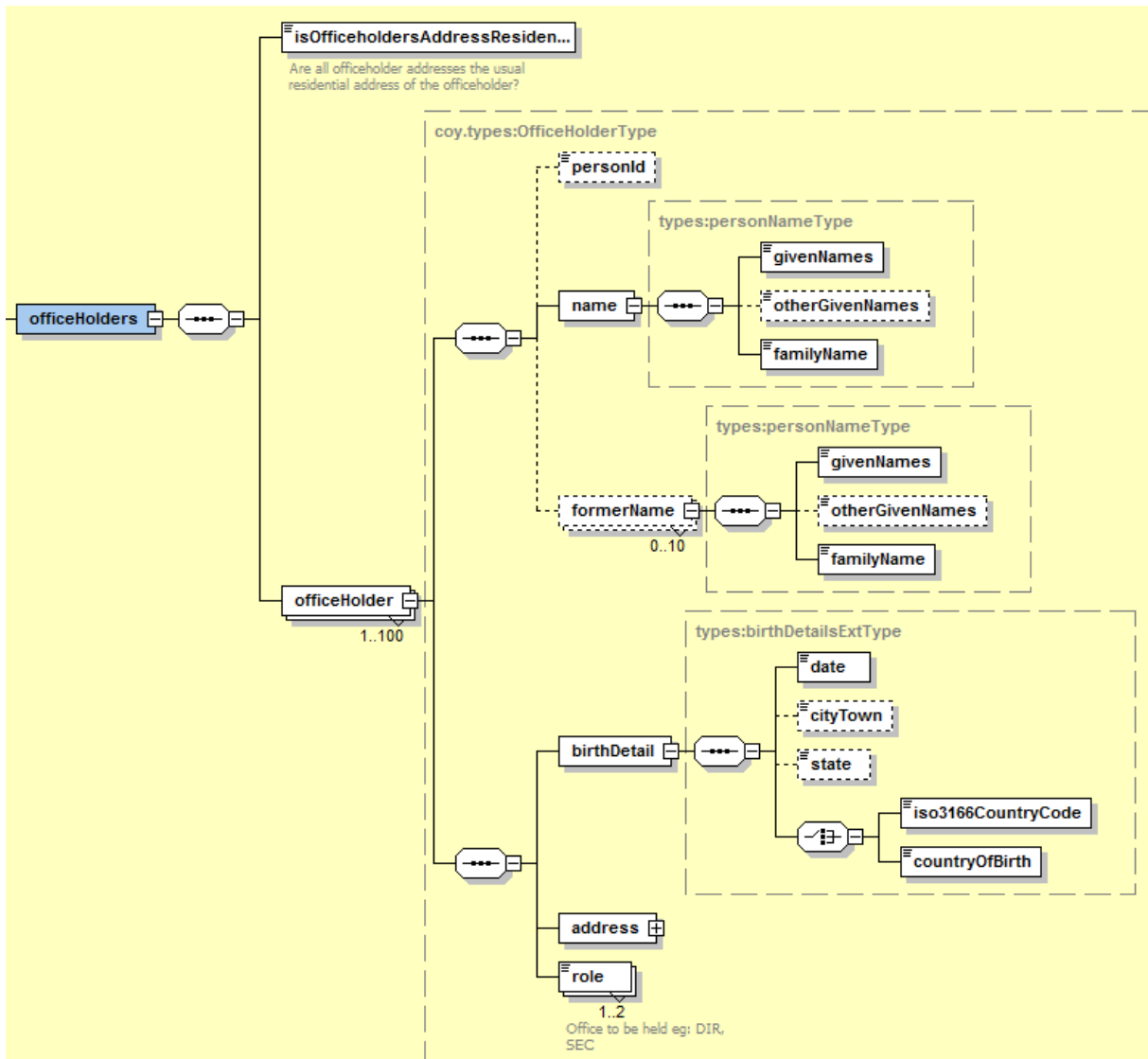
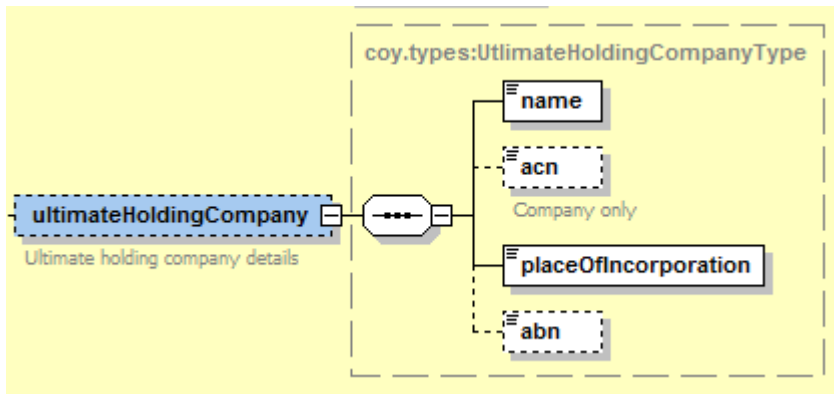

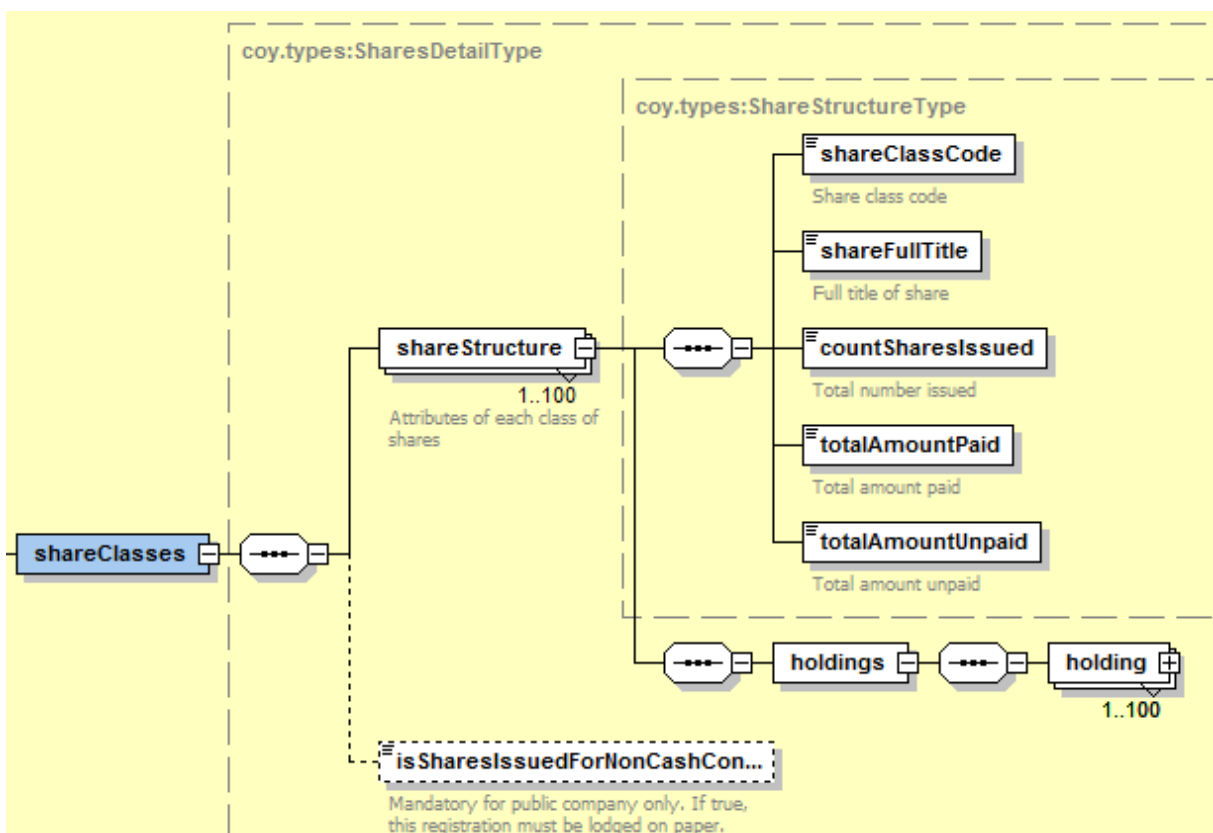
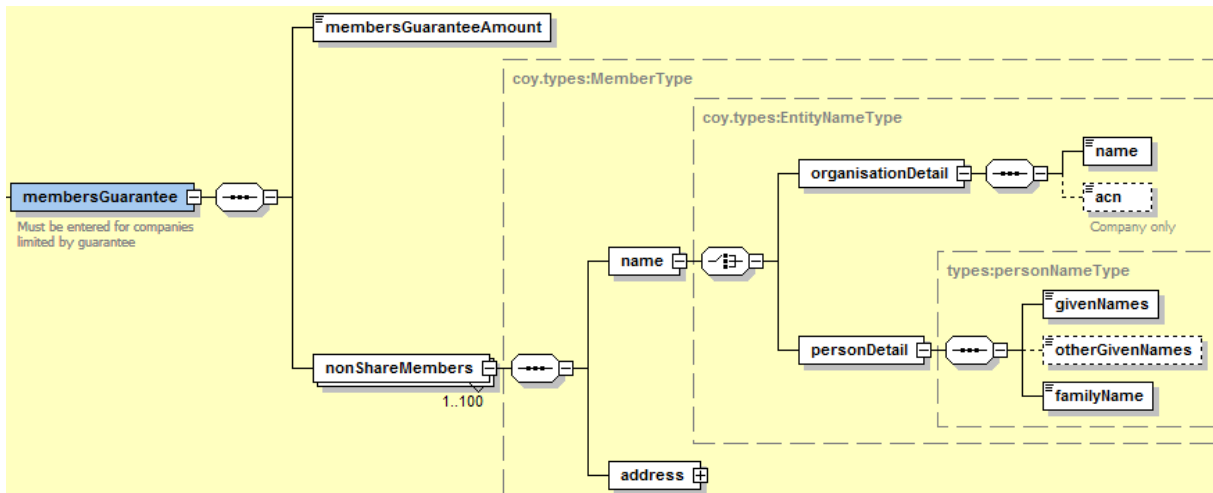

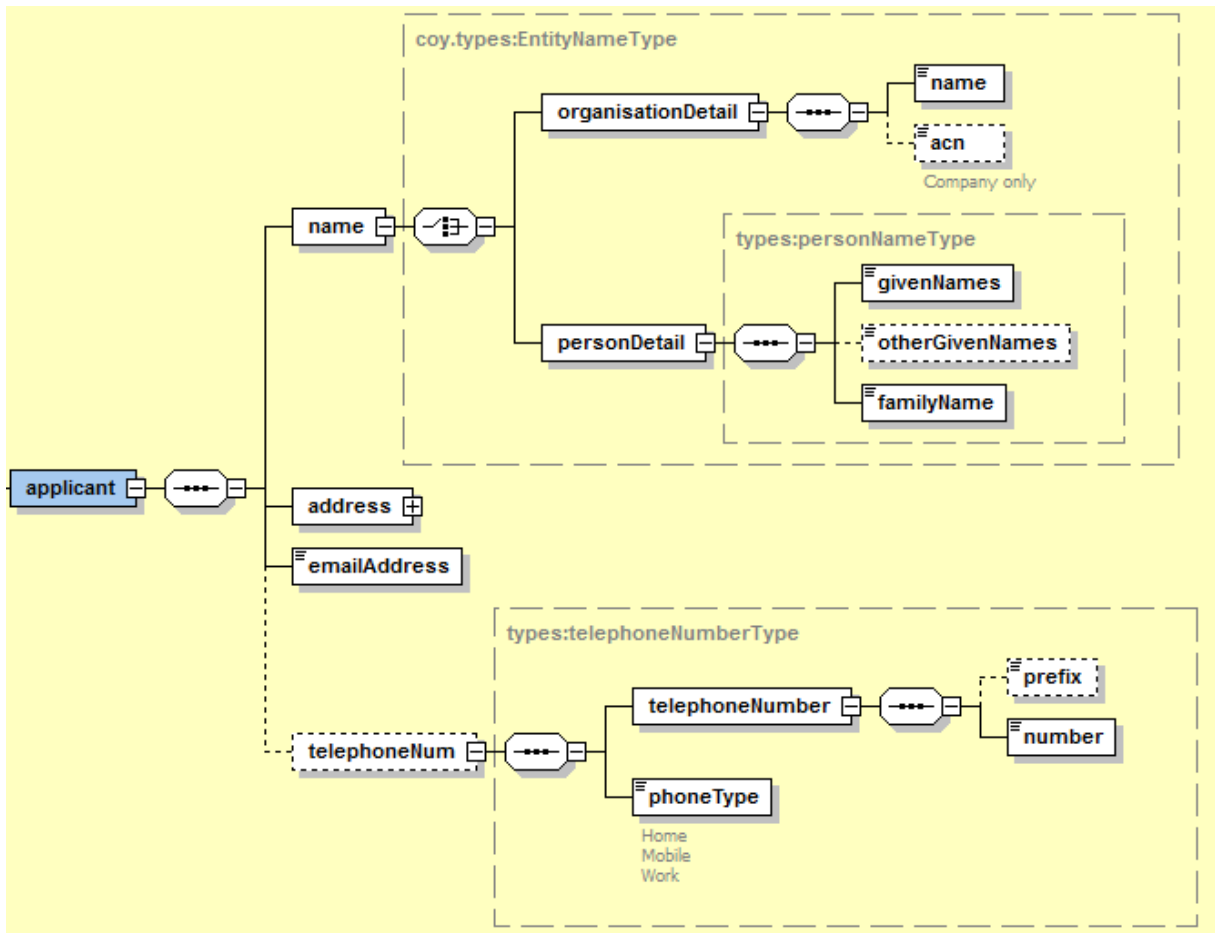
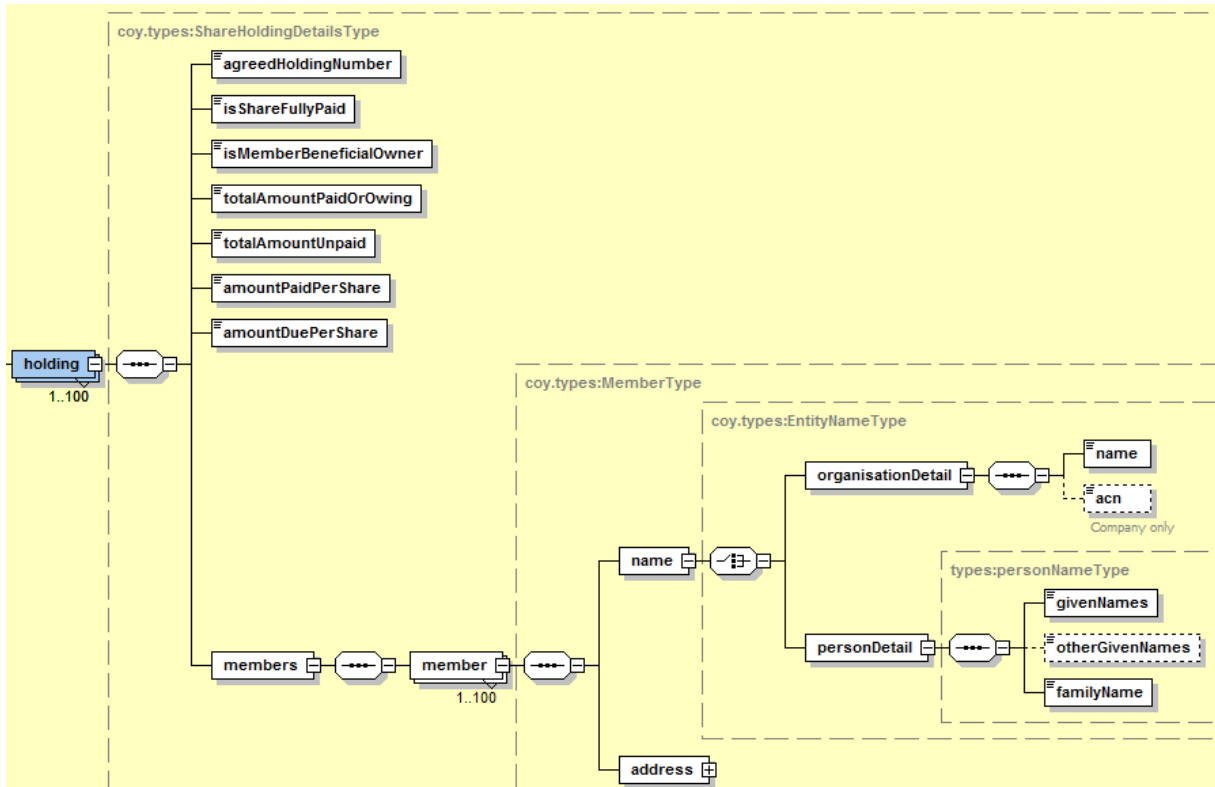

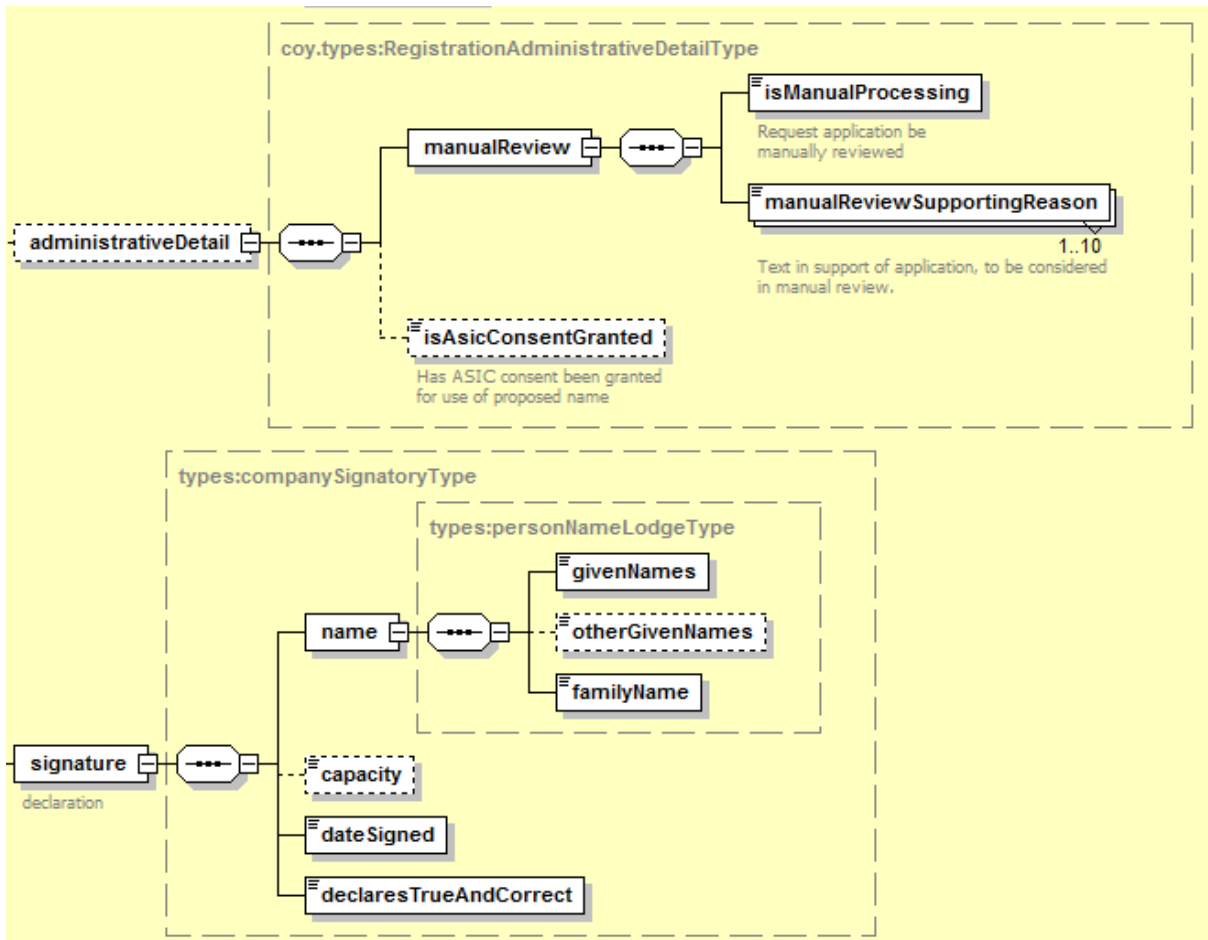

Address type

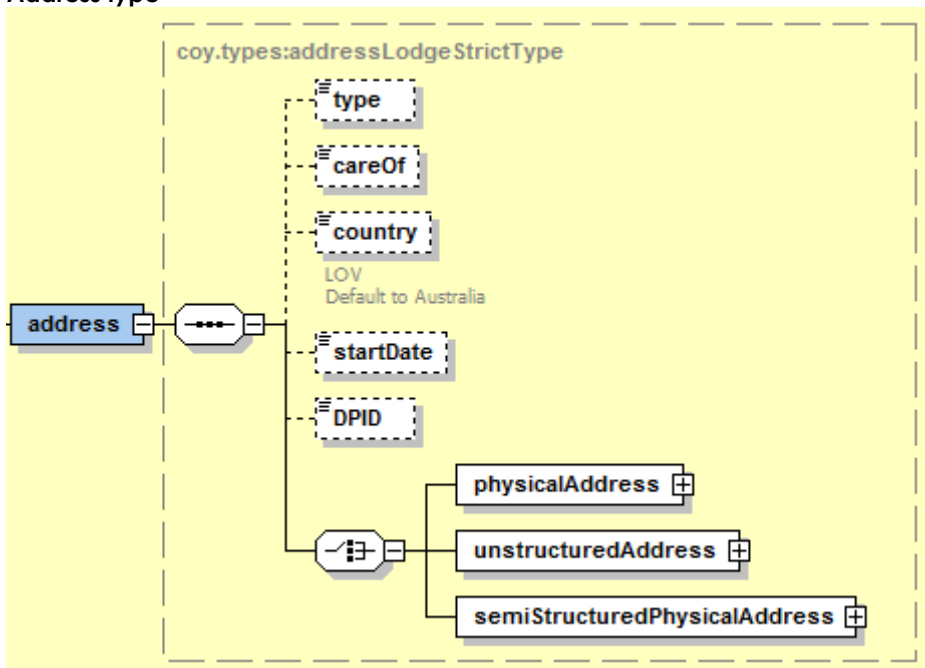

Message Content Table

Seq. No	XML Element	Type	Description	Business Rules/Instructions
1	registrationDetail	Complex content	Contains the details related to company registration	Mandatory
1.1	proposedCompany	Complex content	Proposed name	Mandatory
1.1.1	ACNAsName	Complex content	Contains the prefix and legal element details of proposed company if company is using the ACN as name	<p>Conditional. Either ACNAsName details are provided or companyName is entered. If provided – means that the ACN is to be used as the name. The companyName element must not be completed Not provided – means that the ACN is not to be used as company name. The companyName element must be completed The proposed name in the lodgement must match the proposed name in the initiate payment request.</p> <p>*When the company is using the ACN as name, the lodgement will be rejected if it is required to be reviewed by ASIC. This can be for either of the following:</p> <ul style="list-style-type: none"> • having an officeholder address that is not residential • an officeholder address that has a floor or level • the company has a constitution • the application has been requested to be manually reviewed. <p>If the application does not require a review by ASIC the application will be accepted. If the</p>

				application must have the above criteria, this service cannot be used for lodgement.
1.1.1.1	legalElements	xs:string	The legal elements of the proposed company	Mandatory Minimum length 1 characters Maximum length 20 characters Refer to Appendix E for valid legal element combinations
1.1.2	companyName	types:nniNameType	The proposed company name.	Conditional Either ACNAsName details are provided or companyName is entered. Maximum length 200 characters, including legal elements. Refer to Appendix E for legal elements Must contain valid characters: A to Z 0 to 9 !@# \$ % ^ & * " () ? ; : = _ - / \ . , ' { } The proposed name in the lodgement must match the proposed name in the initiate payment request.
1.2	structure	Complex content	The type & class of the proposed company	Mandatory
1.2.1	companyType	xs:string	The company type, either proprietary or public	Mandatory Valid codes are: <ul style="list-style-type: none"> • APTY - Australian proprietary company • APUB - Australian public company Company type must match the company type in the initiate payment request. See Appendix E for details of valid type/class/subclass combinations.

1.2.2	companyClass	xs:string	The company class indicates how the company is structured	<p>Mandatory Valid codes are:</p> <ul style="list-style-type: none"> • LMGT - Limited by guarantee • LMSH - Limited by shares • NLIA - No liability <p>Company class must match the company class in the initiate payment request.</p> <p>See Appendix E for details of valid type/class/subclass combinations</p>
1.2.3	companySubClasses	xs:string	The company sub class. Sub classes indicates if the company is registered for a special purpose or not	<p>Mandatory Valid codes are:</p> <ul style="list-style-type: none"> • PNPC - Proprietary charitable purposes only • PSTC - Proprietary superannuation trustee company • HUNT - Proprietary home unit company • PROP - Proprietary other • ULSN - Unlisted public charitable purposes only • ULSS - Unlisted public superannuation trustee company • ULST - Unlisted public company <p>Company subclass must match the company subclass in the initiate payment request.</p> <p>See Appendix E for details of valid type/class/subclass combinations</p>
1.3	isGovernedByConstitution	xs:boolean	Indicates if the company is governed by a constitution.	<p>Conditional Must be completed if company type is APUB Must not be provided if company type is APTY Must be 'true' if company class is NLIA</p>

				<p>Must be 'true' if company subclass is ULSN or ULSS</p> <p>If the customer is governed by a constitution they must supply evidence to ASIC. An attachment needs to be emailed to the following mailbox: Production mailbox – ecr.support@asic.gov.au</p>
1.4	reservationDetails	Complex content	Details of name reservation if company name has been reserved	<p>Optional</p> <p>The reservation details must match the details provided in the initiate payment request.</p>
1.4.1	reservationDocumentNumber	xs:string	Contains the ASIC document number of the current name reservation.	<p>Mandatory</p> <p>Length is 9 characters.</p> <p>The reservation document number must be the same as advised during initiate payment. The company name reservation must still be current.</p> <p>The applicant name of the reservation must match the applicant name of the company registration using the name.</p> <p>The reserved company name/type/class must match to the company registration details.</p>
1.5	identicalBusinessNamesOwned	Complex content	Details of the business names that are identical to the company name being registered	<p>Optional</p> <p>The identical business name details must match the details provided in the initiate payment requests.</p> <p>If the business name is not registered under an ABN holder or is exempt from registering under an ABN holder, set "administrativeDetail/manualReview/IsManualProcessing" to "true" and provide the business name details in the "manualReviewSupportingReason" field.</p> <p>If the business name proprietor is a trust a signed copy of the trust deed must be provided to ASIC. An attachment needs to be emailed to the following mailbox:</p>

				Production mailbox – ecr.support@asic.gov.au
1.5.1	businessName	types:nniNameType	Contains the details of the identical business name(s)	Mandatory Maximum length = 200 The BN must exist in the ASIC register
1.5.2	abn	types: abnType	The ABN of the holder of the business name	Conditional Length 11 characters If there is a business name entered, provided either ABN or state business name details (prevBusinessIdentifier elements)
1.5.3	prevBusinessIdentifier	Complex content	Container for previous registration details for business names (before referral of powers to ASIC)	Conditional Maximum occurrence = 8 If there is a business name entered, provided either ABN or state business name details (prevBusinessIdentifier elements)
1.5.3.1	PrevStateName	xs:string	The state in which the BN was previously registered.	Mandatory Must be one of the following values: ACT; NSW; NT; QLD; SA; TAS; VIC; WA
1.5.3.2	PrevStateNumber	xs:string	The number assigned by the state for registration of the business name	Mandatory Maximum length 10 characters
1.6	jurisdictionState	xs:string	The state in which the company is taken to have been registered	Mandatory Must be one of the following values: ACT; NSW; NT; QLD; SA; TAS; VIC; WA
1.7	addresses	Complex content	Address(es) of the proposed company including registered office, principal place of business & email	The following addresses must be provided: <ul style="list-style-type: none"> registered office address principal place of business address
1.7.1	registeredOffice	Complex content	Details of the registered office of the company	Mandatory Must be a valid Australian physical address Must not be a PO Box address

1.7.1.1	address	Complex content	Details of the registered office address of the company	Mandatory
1.7.1.1.1	type	types:addressType	Not relevant for this message	Not used
1.7.1.1.2	careOf	xs:string	Care Of	Optional Maximum length 60 characters
1.7.1.1.3	country	xs:string	Country name as per Appendix C	Optional. Value must be "Australia" in this context.
1.7.1.1.4	startDate	xs:date	The date that this address started being used	Not used
1.7.1.1.5	DPID	xs:string	Post Office Delivery Point Identifier	Optional Maximum length 8 characters
1.7.1.1.6	physicalAddress	Complex content	Contains the data elements required for an Australian address	Conditional Either a physical; or semi structured physical address must be provided. The address must be a valid Australian address.
1.7.1.1.6.1	floorNumber	xs:string	The level of the building	Optional Maximum length 20 characters
1.7.1.1.6.2	propertyName	xs:string	The name of the property	Optional Maximum length 75 characters
1.7.1.1.6.3	unitOrOfficeNumber	xs:string	The unit number	Optional Maximum length 20 characters

1.7.1.1.6.4	streetNumber	xs:string	The street number	Optional Maximum length 20 characters
1.7.1.1.6.5	streetName	xs:string	Street name	Optional Maximum length 75 characters
1.7.1.1.6.6	streetType	xs:string	Street type	Must be a valid type - the list of valid values is available in Appendix C – LIST OF Values
1.7.1.1.6.7	postalDeliveryType	xs:string	The postal delivery type (e.g. PO Box, Locked Bag, etc)	Not used. PO Box and GPO Box addresses are not valid for the registered office address
1.7.1.1.6.8	postalDeliveryNumber	xs:string	The number associated with the postal delivery type	Not used
1.7.1.1.6.9	locality	xs:string	Locality or suburb	Mandatory Maximum length 75 characters Must be formatted in title case (ex: North Sydney)
1.7.1.1.6.10	state	types:stateTerritoryCodeType	Australian state code	Mandatory, valid values are: ACT; NSW; NT; QLD; SA; TAS; VIC; WA
1.7.1.1.6.11	postCode	xs:string	Australian postcode	Mandatory
1.7.1.1.7	unstructuredAddress	Complex content	Contains the data elements required for a foreign address	Not used
1.7.1.1.8	semiStructuredPhysicalAddress	Complex content	Contains the data elements required for an Australian address	Conditional Either a physical or semi structured physical address must be provided. The address must be a valid Australian address.

1.7.1.1.8.1	addressLine1	xs:string	Semi structured address line	Mandatory Maximum length 60 characters Enter an Australian address not including locality, State/Territory and post code.
1.7.1.1.8.2	addressLine2	xs:string	Semi structured address line	Optional Maximum length 60 characters
1.7.1.1.8.3	locality	xs:string	Locality or suburb	Mandatory Maximum length 75 characters Must be formatted in title case (ex: North Sydney)
1.7.1.1.8.4	state	types:stateTerritoryCodeType	Australian state code	Mandatory, valid values are: ACT; NSW; NT; QLD; SA; TAS; VIC; WA
1.7.1.1.8.5	postcCode	xs:string	Australian postcode	Mandatory
1.7.1.2	officeOccupant	Complex content	Registered office	Mandatory
1.7.1.2.1	isOccupiedByCompany	xs:boolean	Will the company occupy the address?	Conditional If provided, value must be true. Otherwise, provide third party occupier details
1.7.1.2.2	thirdParty	xs:string	Details of the occupier of the registered office	Mandatory
1.7.1.2.2.1	occupierName	xs:string	If company will not occupy the registered office, the name of the occupier	Mandatory Maximum length = 200
1.7.1.2.2.2	occupierConsents	xs:boolean	If company will not occupy the registered office, has the occupant's consent been obtained.	Mandatory value must be true
1.7.1.3	officeHours	Complex content	Office hours	Conditional To be completed by public companies only.

1.7.1.3.1	isStandardHours	xs:boolean	Is the registered office to be open each business day from at least 10am to 12 noon and 2pm to 4pm?	Conditional If provided, value must be true. Otherwise, provide trading hours.
1.7.1.4	tradingHour	Complex content	Container for the company trading hours if they do not operate during standard hours	Conditional Maximum occurrence = 9 If the public company is not open during standard hours, the opening and closing hours must be provided. Total opening time must be at least 3 hours between the times of 0900 and 1700
1.7.1.4.1	officeOpeningHour	xs:time	Office hours time of opening	Mandatory
1.7.1.4.2	officeClosingHour	xs:time	Office hours time of closing	Mandatory Closing time must be after opening time
1.7.2	ppob	Complex content	Principal place of business address of the company	Mandatory Must be a valid Australian physical address Must not be a PO Box address
1.7.2.1	type	types:addressType	Not relevant for this message	<ul style="list-style-type: none"> Not used
1.7.2.2	careOf	xs:string	Care Of	Optional Maximum length 60 characters
1.7.2.3	country	xs:string	Country name as per Appendix C	Optional. If not provided it will be defaulted to "Australia"
1.7.2.4	startDate	xs:date	The date that this address started being used	Not used
1.7.2.5	DPID	xs:string	Post Office Delivery Point Identifier	Optional Maximum length 8 characters

1.7.2.6	physicalAddress	Complex content	Contains the data elements required for the Australian addresses	Conditional Either a physical; or semi structured physical address must be provided. The address must be a valid Australian address.
1.7.2.6.1	floorNumber	xs:string	The level of the building	Optional Maximum length 20 characters
1.7.2.6.2	propertyName	xs:string	The name of the property	Optional Maximum length 75 characters
1.7.2.6.3	unitOrOfficeNumber	xs:string	The unit number	Optional Maximum length 20 characters
1.7.2.6.4	streetNumber	xs:string	The street number	Optional Maximum length 20 characters
1.7.2.6.5	streetName	xs:string	Street name	Optional Maximum length 75 characters
1.7.2.6.6	streetType	xs:string	Street type	Must be a valid type - the list of valid values is available in Appendix C – LIST OF Values
1.7.2.6.7	postalDeliveryType	xs:string	The postal delivery type (e.g. PO Box, Locked Bag, etc)	Not used PO Box and GPO Box addresses are not valid for the principal place of business address
1.7.2.6.8	postalDeliveryNumber	xs:string	The number associated with the postal delivery type	Not used
1.7.2.6.9	locality	xs:string	Locality or suburb	Mandatory Maximum length 75 characters Must be formatted in title case (ex: North Sydney)

1.7.2.6.10	state	types:stateTerritoryCodeType	Australian state code	Mandatory, valid values are: ACT; NSW; NT; QLD; SA; TAS; VIC; WA
1.7.2.6.11	postcode	xs:string	Australian postcode	Mandatory
1.7.2.7	unstructuredAddress	Complex content	Contains the data elements required for a foreign address	Not used
1.7.2.8	semiStructuredPhysicalAddress	Complex content	Contains the data elements required for an Australian address	Conditional Either a physical or semi structured physical address must be provided. The address must be a valid Australian address.
1.7.2.8.1	addressLine1	xs:string	Semi structured address line	Mandatory Maximum length 60 characters Enter an Australian address not including locality, State/Territory and post code.
1.7.2.8.2	addressLine2	xs:string	Semi structured address line	Optional Maximum length 60 characters
1.7.2.8.3	locality	xs:string	Locality or suburb	Mandatory Maximum length 75 characters Must be formatted in title case (ex: North Sydney)
1.7.2.8.4	state	types:stateTerritoryCodeType	Australian state code	Mandatory, valid values are: ACT; NSW; NT; QLD; SA; TAS; VIC; WA
1.7.2.8.5	postCode	xs:string	Australian postcode	Mandatory
1.7.3	emailAddress	types:emailType	Contact email address for the company	Not used If sent in the message ASIC will ignore. This will not be stored against the register or available for customers to update if requested.

1.7.4	telephoneNum	xs:string	Phone number of the company	Optional
1.8.	ultimateHoldingCompany	Complex content	Container for details of the Ultimate Holding Company	Optional
1.8.1	name	xs:string	Name of the Ultimate Holding Company	Mandatory Maximum length 200 characters
1.8.2	acn	types:nniNumberType	ACN of the Ultimate Holding Company	Optional, If provided: <ul style="list-style-type: none"> - The number must comply with the ACN algorithm. - The ACN must belong to a company that exists in the ASIC register. - The ACN must belong to a company with status 'registered'. - If ACN provided, the company name must match to the name.
1.8.3	placeOfIncorporation	xs:string	Place of incorporation of the Ultimate Holding Company	Mandatory Maximum length 100 characters
1.8.4	abn	types:abnType	ABN of the Ultimate Holding Company	Optional Length 11 characters Must be a valid value in ABR register. The status of the ABN must be 'current' If ABN provided, the ABN entity name must match the name provided,
1.9	officeholders	Complex content	Container for details of the directors and secretaries of the proposed company	Mandatory All Australian registered companies must have director/s. At least one of the directors must reside in Australia unless the person has ASIC approval to use an alternative address. A proprietary company is not required to appoint a secretary. However, if a secretary is

				<p>appointed, at least one secretary must reside in Australia unless the person has ASIC approval to use an alternative address.</p> <p>A public company must have a minimum of three directors. At least two of the directors must have an Australian residential address unless the person has ASIC approval to use an alternative address.</p> <p>A public company must have a minimum of one secretary with an Australian residential address unless the person has ASIC approval to use an alternative address.</p>
1.9.1	isOfficeholdersAddressResidential	xs:boolean	Are all officeholders' addresses the usual residential address of the officeholder?	<p>Mandatory</p> <p>An address other than the residential address must only be used when an alternate address for an officeholder has been approved under S205D(2) of the Corporations Act 2001. If approval has been given you must request manual review and give the details including the 'ASIC Approval Number' on this application.</p>
1.9.2	officeholder	Complex content	Details of a person appointed for a director and/or secretary role	<p>Mandatory</p> <p>Maximum occurrence = 100</p>
1.9.2.1	personId	xs:string	Internal use only	Not used
1.9.2.2	name	Complex content	Container for the name of the officeholder	Mandatory
1.9.2.2.1	givenNames	xs:string	Given name of the individual	<p>Mandatory</p> <p>Minimum length 1 characters</p> <p>Maximum length 140 characters</p>

1.9.2.2.2	otherGivenNames	xs:string	Other given names	Optional Minimum length 1 characters Maximum length 140 characters
1.9.2.2.3	familyName	xs:string	Family name of the individual	Mandatory Minimum length 2 characters Maximum length 40 characters
1.9.2.3	formerName	Complex content	Former names of the officeholder	Optional Former names must be provided, if any
1.9.2.3.1	givenNames	xs:string	Given name of the individual	Mandatory Minimum length 1 characters Maximum length 140 characters
1.9.2.3.2	otherGivenNames	xs:string	Other given names	Optional Minimum length 1 characters Maximum length 140 characters
1.9.2.3.3	familyName	xs:string	Family name of the individual	Mandatory Minimum length 2 characters Maximum length 40 characters
1.9.2.4	birthDetail	Complex content	Birth details of the individual	Mandatory
1.9.2.4.1	date	xs:date	The date of birth of the officeholder	Mandatory Officeholders must be at least 18 years old.
1.9.2.4.2	cityTown	xs:string	The city or town of birth of the officeholder	Mandatory Maximum length 30 characters
1.9.2.4.3	state	types:stateTerritoryCodeType	Australian state code	Conditional, Must be provided if country of birth is Australia valid values are: ACT; NSW; NT; QLD; SA; TAS; VIC; WA
1.9.2.4.4	iso3166CountryCode	xs:string	Country code for country of birth	Conditional Must provide either country code or country of birth

				Maximum length 2 characters Alpha characters only
1.9.2.4.5	countryOfBirth	xs:string	Country name for country of birth	Conditional Must provide either country code or country of birth Maximum length 75 characters
1.9.2.5	address	Complex content	Address of the officeholder	Mandatory Must be the usual residential address of the officeholder PO Box addresses are not allowed Public companies must have at least 2 directors and at least 1 secretary who ordinarily reside in Australia Proprietary companies must have at least 1 director who ordinarily resides in Australia
1.9.2.5.1	type	types:addressType	Not relevant for this message	Not used
1.9.2.5.2	careOf	xs:string	Care Of	Optional Maximum length 60 characters
1.9.2.5.3	country	xs:string	Country name as per Appendix C	Optional. If not provided it will be defaulted to "Australia"
1.9.2.5.4	startDate	xs:date	The date that this address started being used	Not used
1.9.2.5.5	DPID	xs:string	Post Office Delivery Point Identifier	Optional Maximum length 8 characters
1.9.2.5.6	physicalAddress	Complex content	Contains the data elements required for the Australian addresses	Conditional Either a physical, unstructured or semi structured physical address must be provided. The address must be a valid Australian address.

1.9.2.5.6.1	floorNumber	xs:string	The level of the building	Optional Maximum length 20 characters
1.9.2.5.6.2	propertyName	xs:string	The name of the property	Optional Maximum length 75 characters
1.9.2.5.6.3	unitOrOfficeNumber	xs:string	The unit number	Optional Maximum length 20 characters
1.9.2.5.6.4	streetNumber	xs:string	The street number	Optional Maximum length 20 characters
1.9.2.5.6.5	streetName	xs:string	Street name	Optional Maximum length 75 characters
1.9.2.5.6.6	streetType	xs:string	Street type	Must be a valid type - the list of valid values is available in Appendix C – LIST OF Values
1.9.2.5.6.7	postalDeliveryType	xs:string	The postal delivery type (e.g. PO Box, Locked Bag, etc)	Optional Must be a valid type – the list of values is available in Appendix C – List of Values PO Box and GPO Box addresses are not valid for officeholder addresses
1.9.2.5.6.8	postalDeliveryNumber	xs:string	The number associated with the postal delivery type	Defined in schema as Optional. This element is mandatory for only certain postalDeliveryType enumerations Refer to Appendix C for list of postalDeliveryTypes that require a postalDeliveryNumber
1.9.2.5.6.9	locality	xs:string	Locality or suburb	Mandatory Maximum length 75 characters Must be formatted in title case (ex: North Sydney)

1.9.2.5.6.10	state	types:stateTerritoryCodeType	Australian state code	Mandatory, valid values are: ACT; NSW; NT; QLD; SA; TAS; VIC; WA
1.9.2.5.6.11	postcode	xs:string	Australian postcode	Mandatory Maximum length 12 characters
1.9.2.5.7	unstructuredAddress	Complex content	Contains the data elements required for a foreign address	Conditional Either a physical, unstructured or semi structured physical address must be provided.
1.9.2.5.7.1	addressLine1	xs:string	unstructured address line 1	Mandatory Maximum length 60 characters Enter address starting on line 1.
1.9.2.5.7.2	addressLine2	xs:string	unstructured address line 2	Mandatory Maximum length 60 characters
1.9.2.5.7.3	addressLine3	xs:string	unstructured address line 3	Optional Maximum length 60 characters
1.9.2.5.7.4	addressLine4	xs:string	unstructured address line 4	Optional Maximum length 60 characters
1.9.2.5.8	semiStructuredPhysicalAddress	Complex content	Contains the data elements required for an Australian address	Conditional Either a physical, unstructured or semi structured physical address must be provided. The address must be a valid Australian address.
1.9.2.5.8.1	addressLine1	xs:string	Semi structured address line	Mandatory Maximum length 60 characters Enter an Australian address not including locality, State/Territory and post code.
1.9.2.5.8.2	addressLine2	xs:string	Semi structured address line	Optional Maximum length 60 characters

1.9.2.5.8.3	locality	xs:string	Locality or suburb	Mandatory Maximum length 75 characters Must be formatted in title case (ex: North Sydney)
1.9.2.5.8.4	state	types:stateTerritoryCodeType	Australian state code	Mandatory, valid values are: ACT; NSW; NT; QLD; SA; TAS; VIC; WA
1.9.2.5.8.5	postCode	xs:string	Australian postcode	Mandatory Maximum length 12 characters
1.9.2.6	role	xs:string	Roles held by the officeholder	Mandatory (up to 2 roles) Must be either DIR or SEC Repeats once, that is, a person can be director or secretary or director and secretary A person cannot hold more than 1 director or secretary roles in a company Public companies must have at least 3 directors and at least 1 secretary Proprietary companies must have at least 1 director
1.10	ownershipStructure	Complex content	Ownership/stakeholder & office holding structure of the proposed company	Mandatory Provide members guarantee - non share member details, or share class and share member details.
1.10.1	membersGuarantee	Complex content	Companies limited by guarantee must provide the proposed amount of the guarantee that each member agrees to in writing	Conditional Must be provided if the company class is LMGT
1.10.1.1	membersGuaranteeAmount	xs:positiveInteger	The amount of the guarantee	Must be greater than zero Maximum length 17 characters
1.10.1.2	nonShareMembers	Complex content	Attributes of each non-shareholding member	Optional Must be provided if the company class is LMGT

1.10.1.2.1	name	Complex content	Contains the name details for the non-shareholding member	Mandatory Provide the name of the non share member as a person or an organisation
1.10.1.2.1.1	organisationDetail	Complex content	Name details of the organisation which is a non-shareholding member	Optional Must be provided if the member is an organisation
1.10.1.2.1.1.1	name	xs:string	Name of the organisation	Mandatory Maximum length 200 characters
1.10.1.2.1.1.2	acn	types:nniNumberType	ACN of the organisation	Conditional Is not required for a foreign company, Partnership and Unincorporated entity. If the entity has an ARBN it can be provided. ACN must be provided only for a company registered in Australia. If entered: Must comply with the ACN algorithm. The company must exist in the ASIC register. Company status must be REGD, SOFF, NOAC or EXAD. The company name must match to the member's organisation name
1.10.1.2.1.2	personDetail	types:personNameType	Container for the name of the individual is the non-shareholding member	Optional Not required if the non-shareholding member is an organisation
1.10.1.2.1.2.1	givenNames	xs:string	Given name of the individual	Mandatory Minimum length 1 characters Maximum length 140 characters
1.10.1.2.1.2.2	otherGivenNames	xs:string	Other given names	Optional Minimum length 1 characters Maximum length 140 characters
1.10.1.2.1.2.3	familyName	xs:string	Family name of the individual	Mandatory Minimum length 2 characters Maximum length 40 characters

1.10.1.2.2	address	Complex content	Address details of the non-shareholding member	Mandatory
1.10.1.2.2.1	type	types:addressType	Not relevant for this message	Not used
1.10.1.2.2.2	careOf	xs:string	Care Of	Optional Maximum length 60 characters
1.10.1.2.2.3	country	xs:string	Country name as per ISO3166	Optional. If not provided it will be defaulted to "Australia"
1.10.1.2.2.4	startDate	xs:date	The date that this address started being used	Not used
1.10.1.2.2.5	DPID	xs:string	Post Office Delivery Point Identifier	Optional Maximum length 8 characters
1.10.1.2.2.6	physicalAddress	Complex content	Contains the data elements required for the Australian addresses	Conditional Either a physical, unstructured or semi structured physical address must be provided.
1.10.1.2.2.6.1	floorNumber	xs:string	The level of the building	Optional Maximum length 20 characters
1.10.1.2.2.6.2	propertyName	xs:string	The name of the property	Optional Maximum length 75 characters
1.10.1.2.2.6.3	unitOrOfficeNumber	xs:string	The unit number	Optional Maximum length 20 characters
1.10.1.2.2.6.4	streetNumber	xs:string	The street number	Optional Maximum length 20 characters

1.10.1.2.2.6.5	streetName	xs:string	Street name	Optional Maximum length 75 characters
1.10.1.2.2.6.6	streetType	xs:string	Street type	Must be a valid type - the list of valid values is available in Appendix C – LIST OF Values
1.10.1.2.2.6.7	postalDeliveryType	xs:string	The postal delivery type (e.g. PO Box, Locked Bag, etc)	Optional Must be a valid type – the list of values is available in Appendix C – List of Values
1.10.1.2.2.6.8	postalDeliveryNumber	xs:string	The number associated with the postal delivery type	Defined in schema as Optional. This element is mandatory for only certain postalDeliveryType enumerations Refer to Appendix C for list of postalDeliveryTypes that require a postalDeliveryNumber
1.10.1.2.2.6.9	locality	xs:string	Locality or suburb	Mandatory Maximum length 75 characters Must be formatted in title case (ex: North Sydney)
1.10.1.2.2.6.10	state	types:stateTerritoryCodeType	Australian state code	Mandatory, valid values are: ACT; NSW; NT; QLD; SA; TAS; VIC; WA;
1.10.1.2.2.6.11	postcode	xs:string	Australian postcode	Mandatory Maximum length 12 characters
1.10.1.2.2.7	unstructuredAddress	Complex content	Contains the data elements required for a foreign address	Conditional Either a physical, unstructured or semi structured physical address must be provided.
1.10.1.2.2.7.1	addressLine1	xs:string	unstructured address line 1	Mandatory Enter address starting on line 1. Maximum length 60 characters
1.10.1.2.2.7.2	addressLine2	xs:string	unstructured address line 2	Mandatory Maximum length 60 characters

1.10.1.2.2.7.3	addressLine3	xs:string	unstructured address line 3	Optional Maximum length 60 characters
1.10.1.2.2.7.4	addressLine4	xs:string	unstructured address line 4	Optional Maximum length 60 characters
1.10.1.2.2.8	semiStructuredPhysicalAddress	Complex content	Contains the data elements required for an Australian address	Conditional Either a physical, unstructured or semi structured physical address must be provided.
1.10.1.2.2.8.1	addressLine1	xs:string	Semi structured address line	Mandatory Enter an Australian address not including locality, State/Territory and post code. Maximum length 60 characters
1.10.1.2.2.8.2	addressLine2	xs:string	Semi structured address line	Optional Maximum length 60 characters
1.10.1.2.2.8.3	locality	xs:string	Locality or suburb	Mandatory Maximum length 75 characters Must be formatted in title case (ex: North Sydney)
1.10.1.2.2.8.4	state	types:stateTerritoryCodeType	Australian state code	Mandatory, valid values are: ACT; NSW; NT; QLD; SA; TAS; VIC; WA
1.10.1.2.2.8.5	postCode	xs:string	Australian postcode	Mandatory Maximum length 12 characters
1.10.2	shareClasses	Complex content	Contains details of the share structure and of the shareholding members and non-shareholding members	Conditional All Australian companies must have a share structure except a public company limited by guarantee. Shares held as a trustee, nominee or on account of another person are held non-beneficially.

				Shares held by a trust must provide the details of each trustee as the non-beneficial member instead of the name of the trust as the member.
1.10.2.1	shareStructure	Complex content	Attributes of each share class	Mandatory
1.10.2.1.1	shareClassCode	xs:string	Share class code	Mandatory Maximum length 4 characters The standard share codes may be used. Refer to table Standard share classes in appendix E Share class codes cannot be duplicated.
1.10.2.1.2	shareFullTitle	xs:string	Full title of share class	Mandatory Maximum length 60 characters
1.10.2.1.3	countSharesIssued	xs:positiveInteger	Total number of shares issued in the share class	Mandatory Minimum value = 1 Maximum length = 17 The total number of all shares taken up for each share class must equal the total number of shares in the share structure for the same share class.
1.10.2.1.4	totalAmountPaid	xs:positiveInteger	Total amount paid for all shares issued in the share class	Mandatory Minimum value = 0 Maximum value = 9999999999999999.99
1.10.2.1.5	totalAmountUnpaid	xs:positiveInteger	Total amount unpaid for all shares issued in the share class	Mandatory Minimum value = 0 Maximum value = 9999999999999999.99
1.10.2.1.6	holdings	Complex content	Attributes of each shareholding member	Mandatory
1.10.2.1.6.1	holding	Complex content	Details of shares held by a shareholding member	Mandatory Maximum occurrence = 100

1.10.2.1.6.1.1	agreedHoldingNumber	xs:positiveInteger	Indicates the total number of shares taken up for the holding.	Mandatory Maximum length = 17
1.10.2.1.6.1.2	isShareFullyPaid	xs:boolean	Indicates if shares have been fully paid for this holding	Mandatory
1.10.2.1.6.1.3	isMemberBeneficialOwner	xs:boolean	Indicates if shares are beneficially held for this holding	Mandatory
1.10.2.1.6.1.4	totalAmountPaidOrOwing	xs:positiveInteger	Total amount paid for all shares held in the holding	Mandatory Minimum value = 0 Maximum value = 9999999999999999.99
1.10.2.1.6.1.5	totalAmountUnpaid	xs:positiveInteger	Total amount unpaid for all shares held in the holding	Mandatory Minimum value = 0 Maximum value = 9999999999999999.99
1.10.2.1.6.1.6	amountPaidPerShare	xs:positiveInteger	Amount paid per share in the holding	Mandatory Minimum value = 0 Maximum value = 9999999999999999.99
1.10.2.1.6.1.7	amountDuePerShare	xs:positiveInteger	Amount unpaid per share in the holding	Mandatory Minimum value = 0 Maximum value = 9999999999999999.99
1.10.2.1.6.1.8	members	Complex content	Name and address of the shareholding members	Mandatory
1.10.2.1.6.1.8.1	member	Complex content	Name and address of each shareholding members	Mandatory Maximum occurrence = 100
1.10.2.1.6.1.8.1.1	name	Complex content	Name details of the shareholding member	Mandatory Maximum length 200 characters Provide the name of the share member as a person or an organisation
1.10.2.1.6.1.8.1.1.1	organisationDetail	Complex content	Name details of the organisation which is a shareholding member	Optional Name of the share member where they are an organisation

1.10.2.1.6.1.8.1.1.1	name	xs:string	Name of the organisation	Mandatory Maximum length 200 characters
1.10.2.1.6.1.8.1.1.2	acn	types:nniNumberType	ACN of the organisation	Conditional Is not required for a foreign company, Partnership and Unincorporated entity. If the entity has an ARBN it can be provided. ACN must be provided only for a company registered in Australia. If entered: Must comply with the ACN algorithm. The company must exist in the ASIC register. Company status must be REGD, SOFF, NOAC or EXAD. The company name must match to the member's organisation name
1.10.2.1.6.1.8.1.1.2	personDetail	types:personNameType	Container for the name of the individual who holds shares	Optional Name of the share member where they are an individual. Not required if the shareholding member is an organisation
1.10.2.1.6.1.8.1.1.2.1	givenNames	xs:string	Given name of the individual	Mandatory Minimum length 1 characters Maximum length 140 characters
1.10.2.1.6.1.8.1.1.2.2	otherGivenNames	xs:string	Other given names	Optional Minimum length 1 characters Maximum length 140 characters
1.10.2.1.6.1.8.1.1.2.3	familyName	xs:string	Family name of the individual	Mandatory Minimum length 2 characters Maximum length 40 characters
1.10.2.1.6.1.8.1.2	address	Complex content	The address of the shareholding member	Mandatory

1.10.2.1.6.1.8.1.2.1	type	types:addressType	Not relevant for this message	Not used
1.10.2.1.6.1.8.1.2.2	careOf	xs:string	Care Of	Optional Maximum length 60 characters
1.10.2.1.6.1.8.1.2.3	country	xs:string	Country name as per Appendix C	Optional. If not provided it will be defaulted to "Australia"
1.10.2.1.6.1.8.1.2.4	startDate	xs:date	The date that this address started being used	Not used
1.10.2.1.6.1.8.1.2.5	DPID	xs:string	Post Office Delivery Point Identifier	Optional Maximum length 8 characters
1.10.2.1.6.1.8.1.2.6	physicalAddress	Complex content	Contains the data elements required for the Australian addresses	Mandatory Both addresses must be Australian addresses
1.10.2.1.6.1.8.1.2.6.1	floorNumber	xs:string	The level of the building	Optional Maximum length 20 characters
1.10.2.1.6.1.8.1.2.6.2	propertyName	xs:string	The name of the property	Optional Maximum length 75 characters
1.10.2.1.6.1.8.1.2.6.3	unitOrOfficeNumber	xs:string	The unit number	Optional Maximum length 20 characters
1.10.2.1.6.1.8.1.2.6.4	streetNumber	xs:string	The street number	Optional Maximum length 20 characters
1.10.2.1.6.1.8.1.2.6.5	streetName	xs:string	Street name	Optional Maximum length 75 characters

1.10.2.1.6.1.8.1.2.6.6	streetType	xs:string	Street type	Must be a valid type - the list of valid values is available in Appendix C – LIST OF Values
1.10.2.1.6.1.8.1.2.6.7	postalDeliveryType	xs:string	The postal delivery type (e.g. PO Box, Locked Bag, etc)	Optional Must be a valid type – the list of values is available in Appendix C – List of Values
1.10.2.1.6.1.8.1.2.6.8	postalDeliveryNumber	xs:string	The number associated with the postal delivery type	Defined in schema as Optional. This element is mandatory for only certain postalDeliveryType enumerations Refer to Appendix C for list of postalDeliveryTypes that require a postalDeliveryNumber
1.10.2.1.6.1.8.1.2.6.9	locality	xs:string	Locality or suburb	Mandatory Maximum length 75 characters Must be formatted in title case (ex: North Sydney)
1.10.2.1.6.1.8.1.2.6.10	state	types:stateTerritoryCodeType	Australian state code	Mandatory, valid values are: ACT; NSW; NT; QLD; SA; TAS; VIC; WA;
1.10.2.1.6.1.8.1.2.6.11	postcode	xs:string	Australian postcode	Mandatory Maximum length 12 characters
1.10.2.1.6.1.8.1.2.7	unstructuredAddress	Complex content	Contains the data elements required for an Australian address	Conditional Either a physical, unstructured or semi structured physical address must be provided.
1.10.2.1.6.1.8.1.2.7.1	addressLine1	xs:string	unstructured address line 1	Mandatory Enter address starting on line 1. Maximum length 60 characters
1.10.2.1.6.1.8.1.2.7.2	addressLine2	xs:string	unstructured address line 2	Mandatory Maximum length 60 characters
1.10.2.1.6.1.8.1.2.7.3	addressLine3	xs:string	unstructured address line 3	Optional Maximum length 60 characters

1.10.2.1.6.1.8.1.2.7.4	addressLine4	xs:string	unstructured address line 4	Optional Maximum length 60 characters
1.10.2.1.6.1.8.1.2.8	semiStructuredPhysicalAddress	Complex content	Contains the data elements required for an Australian address	Conditional Either a physical, unstructured or semi structured physical address must be provided.
1.10.2.1.6.1.8.1.2.8.1	addressLine1	xs:string	Semi structured address line	Mandatory Maximum length 60 characters Enter an Australian address not including locality, State/Territory and post code.
1.10.2.1.6.1.8.1.2.8.2	addressLine2	xs:string	Semi structured address line	Optional Maximum length 60 characters
1.10.2.1.6.1.8.1.2.8.3	locality	xs:string	Locality or suburb	Mandatory Maximum length 75 characters Must be formatted in title case (ex: North Sydney)
1.10.2.1.6.1.8.1.2.8.4	state	types:stateTerritoryCodeType	Australian state code	Mandatory, valid values are: ACT; NSW; NT; QLD; SA; TAS; VIC; WA
1.10.2.1.6.1.8.1.2.8.5	postCode	xs:string	Australian postcode	Mandatory Maximum length 12 characters
1.10.2.2	isSharesIssuedForNonCashConsideration	xs:boolean	Indicates if shares have issued for a non-cash consideration	Conditional. Not required for proprietary company. Mandatory for public company only (not LMGT). If shares have been issued for non cash consideration, the company registration application must be lodged on paper.

2	applicant	Complex content	Details of the company registration applicant	Mandatory The applicant details will be displayed on the public document
2.1	name	Complex content	The person or organisation name of the applicant.	Mandatory Must provide the name of the applicant
2.1.1	organisationDetail	Complex content	Container for the name of the company who applied for the company registration	Conditional Either provide the details of the applicant as a person or an organisation Not required if the applicant is a natural person
2.1.1.1	name	xs:string	Name of the company	Mandatory Must match the name as per ASIC records Maximum length 200 characters
2.1.1.2	acn	types:nniNumberType	ACN of the company	Optional Must comply with the ACN algorithm – refer to Appendix D Must belong to a company that exists in ASIC register
2.1.2	personDetail	types:personNameType	Container for the name of the individual who applied for the company registration	Conditional Either provide the details of the applicant as a person or an organisation Not required if the applicant is an organisation
2.1.2.1	givenNames	xs:string	Given name of the applicant	Mandatory Minimum length 1 characters Maximum length 140 characters
2.1.2.2	otherGivenNames	xs:string	Other given names of the applicant	Optional Minimum length 1 characters Maximum length 140 characters
2.1.2.3	familyName	xs:string	Family name of the applicant	Mandatory Minimum length 2 characters Maximum length 40 characters

2.2	address	Complex content	Contact address details of the applicant.	Must be a valid address
2.2.1	type	types:addressType	Not relevant for this message	Not used
2.2.2	careOf	xs:string	Care Of	Optional Maximum length 60 characters
2.2.3	country	xs:string	Country name as per Appendix C	Optional. If not provided it will be defaulted to "Australia"
2.2.4	startDate	xs:date	The date that this address started being used	Not used
2.2.5	DPID	xs:string	Post Office Delivery Point Identifier	Optional Maximum length 8 characters
2.2.6	physicalAddress	Complex content	Contains the data elements required for the Australian addresses	Conditional Either a physical; unstructured or semi structured physical address must be provided.
2.2.6.1	floorNumber	xs:string	The level of the building	Optional Maximum length 20 characters
2.2.6.2	propertyName	xs:string	The name of the property	Optional Maximum length 75 characters
2.2.6.3	unitOrOfficeNumber	xs:string	The unit number	Optional Maximum length 20 characters
2.2.6.4	streetNumber	xs:string	The street number	Optional Maximum length 20 characters

2.2.6.5	streetName	xs:string	Street name	Optional Maximum length 75 characters
2.2.6.6	streetType	xs:string	Street type	Must be a valid type - the list of valid values is available in Appendix C – LIST OF Values
2.2.6.7	postalDeliveryType	xs:string	The postal delivery type (e.g. PO Box, Locked Bag, etc)	Optional Must be a valid type – the list of values is available in Appendix C – List of Values
2.2.6.8	postalDeliveryNumber	xs:string	The number associated with the postal delivery type	Defined in schema as Optional. This element is mandatory for only certain postalDeliveryType enumerations Refer to Appendix C for list of postalDeliveryTypes that require a postalDeliveryNumber
3.2.6.9	Locality	xs:string	Locality or suburb	Mandatory Maximum length 75 characters Must be formatted in title case (ex: North Sydney)
2.2.6.10	State	types:stateTerritoryCodeType	Australian state code	Mandatory, valid values are: ACT; NSW; NT; QLD; SA; TAS; VIC; WA;
2.2.6.11	postcode	xs:string	Australian postcode	Mandatory Maximum length 12 characters
2.2.7	unstructuredAddress	Complex content	Contains the data elements required for a foreign address	Conditional Either a physical; unstructured or semi structured physical address must be provided.
2.2.7.1	addressLine1	xs:string	unstructured address line 1	Mandatory Enter address starting on line 1. Maximum length 60 characters
2.2.7.2	addressLine2	xs:string	unstructured address line 2	Mandatory Maximum length 60 characters

2.2.7.3	addressLine3	xs:string	unstructured address line 3	Optional Maximum length 60 characters
2.2.7.4	addressLine4	xs:string	unstructured address line 4	Optional Maximum length 60 characters
2.2.8	semiStructuredPhysicalAddress	Complex content	Contains the data elements required for an Australian address	Conditional Either a physical; unstructured or semi structured physical address must be provided.
2.2.8.1	addressLine1	xs:string	Semi structured address line	Mandatory Maximum length 60 characters Enter an Australian address not including locality, State/Territory and post code.
2.2.8.2	addressLine2	xs:string	Semi structured address line	Optional Maximum length 60 characters
2.2.8.3	locality	xs:string	Locality or suburb	Mandatory Maximum length 75 characters Must be formatted in title case (ex: North Sydney)
2.2.8.4	state	types:stateTerritoryCodeType	Australian state code	Mandatory, valid values are: ACT; NSW; NT; QLD; SA; TAS; VIC; WA
2.2.8.5	postCode	xs:string	Australian postcode	Mandatory Maximum length 12 characters
2.3	emailAddress	types:emailType	Contact email address.	Mandatory Minimum length 1 characters Maximum length 200 characters If provided, the company certificate will be emailed to this address.
2.4	telephoneNum	types:telephoneNumberType	Telephone contact details	Optional

2.4.1	telephoneNumber	Complex content	Contact telephone number	Mandatory
2.4.1.1	prefix	xs:string	Telephone number prefix, eg country code or area code	Optional
2.4.1.2	number	xs:string	Telephone number	Mandatory
2.4.2	phoneType	xs:string	Contact telephone number type	Mandatory Valid values: - Home - Mobile - Work
3	administrativeDetail	Complex content	Request for manual review and providing information in support of this application	Optional Manual determination will be required if: - ASIC consent is required to use the proposed company name; - Ministerial consent is required; - Query name availability on the proposed company name returns a rejected name result and the applicant wish to proceed with the name; - The proposed name is identical to a business name that is not registered under an ABN entity holder.
3.1	manualReview	Complex content	Details of manual review	Mandatory
3.1.1	isManualProcessing	xs:boolean	Request application be manually reviewed	Mandatory Set value to 'true'. The manual determination flag should be set the same as the initiate payment request.

3.1.2	manualReviewSupportingReason	xs:string	Text in support of application to be considered in manual review	Mandatory Maximum occurrence = 10 Maximum length 80 characters Must be supplied if manual review has been requested.
3.2	isAsicConsentGranted	xs:boolean	Has ASIC consent been granted for use of the proposed company name?	Conditional Must be answered if the company name requires ministerial consent. If the customer has consent has to use the name, they must supply evidence to ASIC. An attachment needs to be emailed to the following mailbox: Production mailbox – ecr.support@asic.gov.au Test mailbox – sbrp.test@asic.gov.au
4	signature	Complex content	Declaration from the applicant or their authorised person confirming all information provided is true & correct.	Mandatory
4.1	name	Complex content	Signatory name details	Mandatory
4.1.1	givenNames	xs:string	Given name of the signatory	Mandatory Minimum length 1 characters Maximum length 140 characters
4.1.2	otherGivenNames	xs:string	Other given names of the signatory	Optional Minimum length 1 characters Maximum length 140 characters
4.1.3	familyName	xs:string	Family name of the signatory	Mandatory Minimum length 2 characters Maximum length 40 characters
4.2	capacity	Complex content	The role the signatory holds in the organisation if the applicant is an organisation	Conditional Must be completed if the applicant is an organisation. Valid values are: DIR - Director SEC - Secretary

				AGT – Agent
4.3	dateSigned	xs:date	Signature date	Mandatory Must not be a future date The date signed must not be more than 6 months in the past.
4.4	declaresTrueAndCorrect	xs:boolean	The applicant view and assent to the declarations as detailed at Section 3.2	Mandatory Refer to Section 3.2.

9.7.4. companyLodgement Reply Message

Business Document Header

The WIG provides the standard specification of the Business Document Header. The following table specifies the message level specific data element values or any variations to the WIG.

Element Name	Instructions / Rules
asicTransactionNumber	Mandatory – transaction unique identifier assigned by ASIC for this transaction

Business Document Body

The 'businessDocumentBody' segment will be returned if the message does not contain any validation errors. If the application is rejected on names determination or requires manual determination, the "notProcessed" segment will provide the details. If the company is registered, the 'accepted' segment will contain the ACN and URL of the company registration certificate.

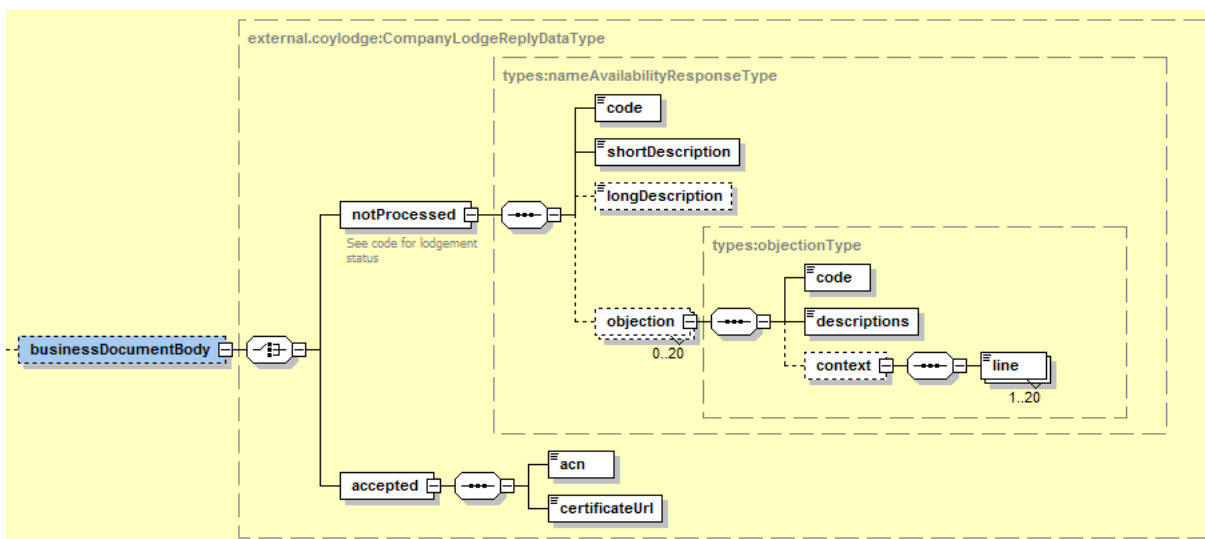

Message Content Table

Seq. No	XML Element	Type	Description
1	notProcessed	Complex content	Indicates the result of the name assessment for the proposed company upon rejection of the application.
1.1	code	xs:string	Will return one of the following valid values : Unavailable –the name can't be used and the user should propose another name SubjectToNamesDetermination –the application is referred to ASIC staff for manual determination Identical – meaning the name is identical to another name and it may be rejected or referred to manual determination
1.2	shortDescription	xs:string	A short text description associated with the code (as listed above) and it provides the result of the name availability check done as part of the validations for the application being submitted
1.3	longDescription	xs:string	A long text description associated with the codes (as listed above) and it provides the result of the name availability check done as part of the validations for the application being submitted
1.4	objections	Complex content	Returned only when the proposed name is unavailable or it is subject to name determination. It contains a code and a description and indicates the reason for the decision.
1.4.1	code	xs:string	The code used by ASIC for the objections. It is returned only if the name is unavailable or is referred to manual processing. Refer to appendix E for some examples of likely name availability objection codes. Please note that is best to develop a generic process to display the code and description as opposed to hard coding these. ASIC may in time choose to tweak or embellish upon the objection descriptions.

1.4.2	description	xs:string	The description associated with the code of the objections.
1.4.3	context	complexType	Additional information returned when the name is identical or near identical to another existing name.
1.4.3.1	line	xs:string	Contains the ASIC internal identifier for a business name or Australian Company Number and the company name that resulted in the exact match (i.e. the existing registered name).
2	accepted	complexType	Optional If registration is successful, this element contains details of the newly registered company
2.1	acn	xs:string	The Australian Company Number of the newly registered company
2.2	certificateUrl	xs:string	The URL of the PDF of the company certificate of the newly registered company.

9.8. MESSAGE SPECIFICATION - reservationLodgement

9.8.1. Business Overview

This web service allows the lodgement of an application for reservation of a company name for an Australian company.

Lodgement of a company name reservation request will initiate a process that will result in either the reservation of the requested company name, or the rejection of the request.

While the aim of this is to provide rapid, automatic processing of requests, ASIC processing of a company name reservation request is a multi-step process that may involve manual processing. Consequently there may be a time delay between the transmission of the request and the reservation (or rejection) of the company.

This service works in 2 modes:

- Validate Only – to verify that the company reservation request is valid and can be processed if need be.
- Process – to submit the application to reserve a company name. This is called after the payment is done and allows the client to lodge their request to register a company.

The 'process' mode of the interface will:

- e) Validate the request details against the schema;
- f) Confirm the validity of the request by looking up the Transaction Reference Number;
- g) Confirm the name availability; and
- h) Initiate the process to reserve the company name.

The 'validate only' mode will do steps a-c and then call the backend to validate the request is able to be processed, if the need be.

If a message is sent to this interface and passes validations and name availability check, the company name is registered on the ASIC National Names Index until the name is reserved or the application is rejected.

Request includes:

- The proposed name, including legal elements, of the company;
- An indication whether the proposed company name is identical to a registered business name. If the name of the proposed company is identical to a registered business name details of the business name must be provided;
- The type and class of the proposed company;

Response includes:

- result of the name assessment performed after the lodgement of the application;
- the result for the lodgement that indicate if the application is accepted or rejected. If rejected it will also indicate the reasons.

9.8.2. HTTPS Connections & WSDL

The requestor's code must establish a HTTPS connection to the appropriate endpoint using the standard port 443.

Environment	WSDL
Production	https://www.gateway.asic.gov.au/gateway/ExternalReservationLodgementPort?WSDL
Test	https://www.gateway.uat.asic.gov.au/gateway/ExternalReservationLodgementPort?WSDL

9.8.3. reservationLodgement Request Message

Business Document Body

The WIG provides the specification of the Business Document Header. The following table specifies the message specific data element values or any variations to the WIG.

Element Name	Instructions / Rules	Error code
MessageType	Mandatory, value must be reservationLodgement	00002
MessageVersion	Mandatory , value must be 1	00004
senderType	Mandatory, value must be REGA	00005
senderId	The identifier assigned by ASIC on registration	00005
transactionReferenceNumber	The Transaction Reference Number advised by the software client. Must be included for applications prepaid using Initiate Payment message. Mandatory, value must be unique for your transactions Application transaction must be in progress Only required for a PROCESS mode request	00116 00125 00114
processMode	Indicates desired processing option. Valid values: - PROCESS – application is to be submitted for processing. - VALIDATE – application is to be validated without submission for processing.	00144

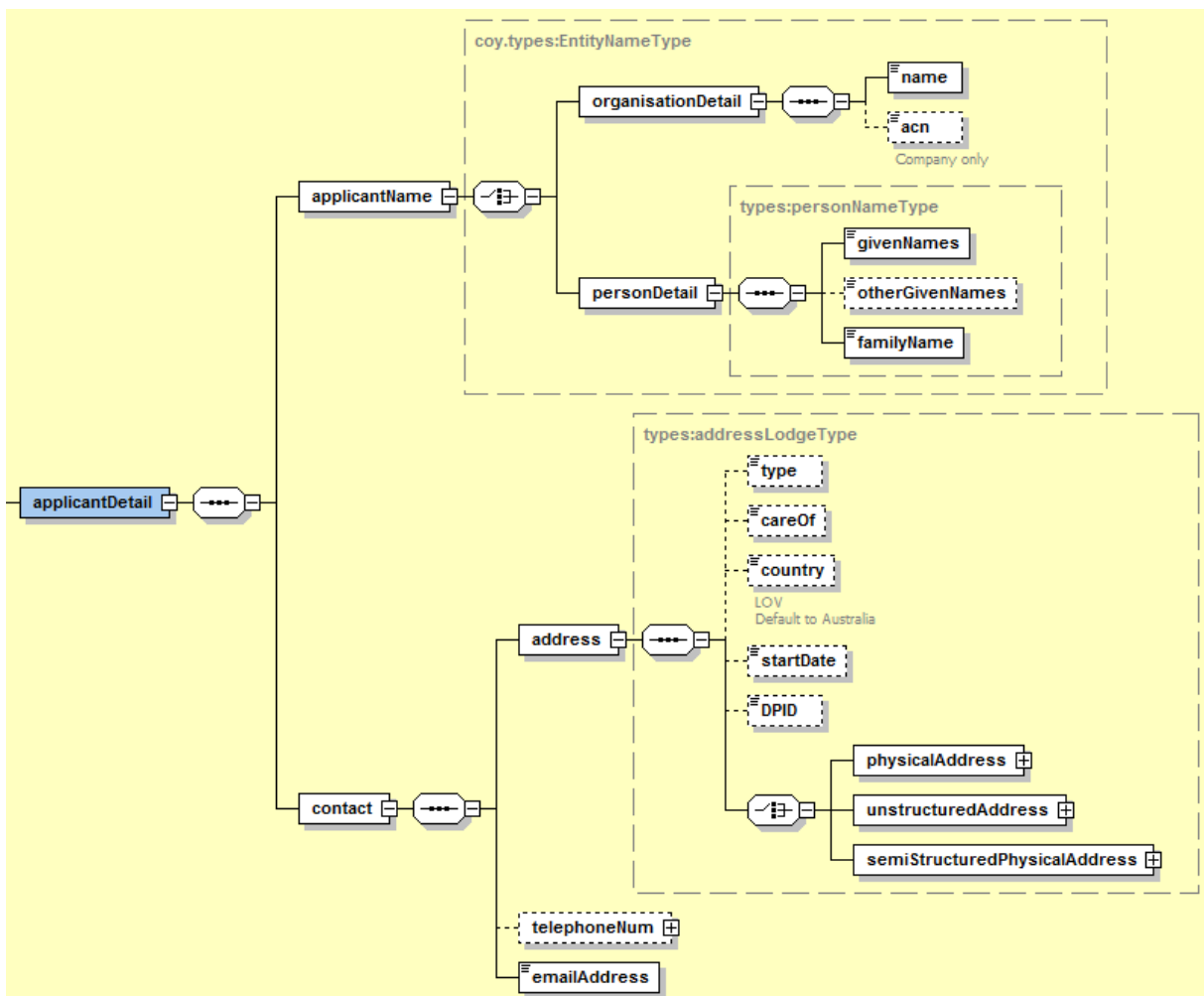
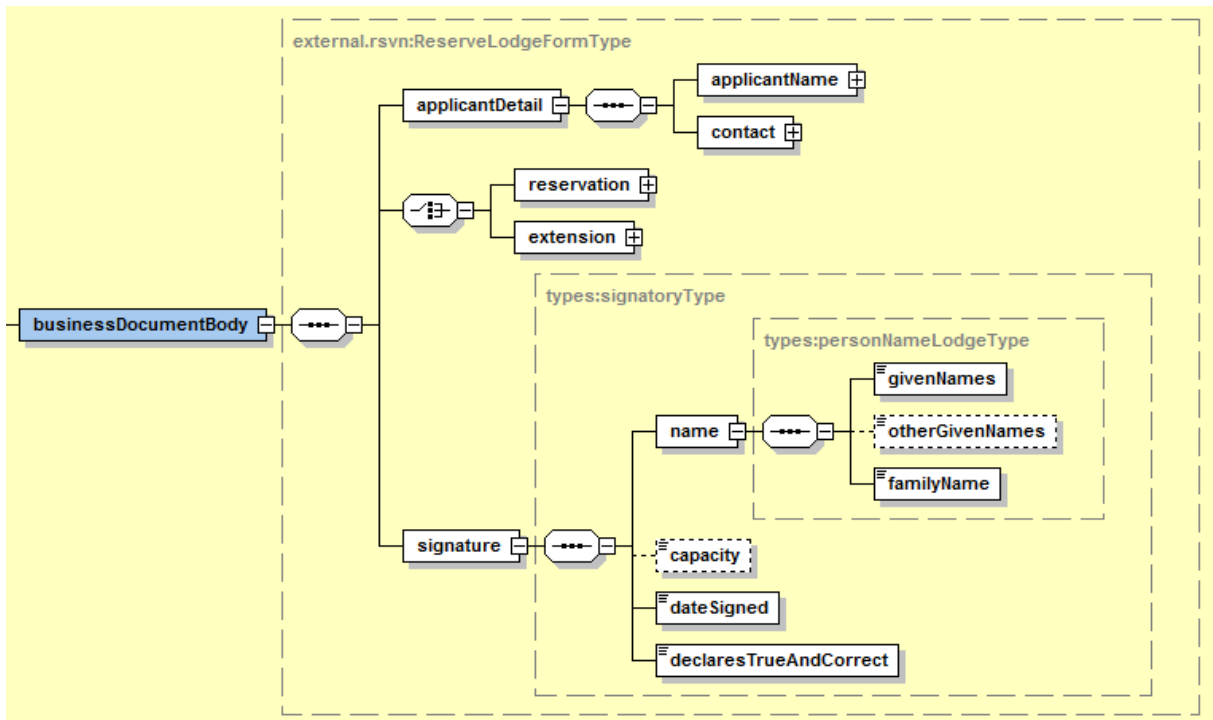

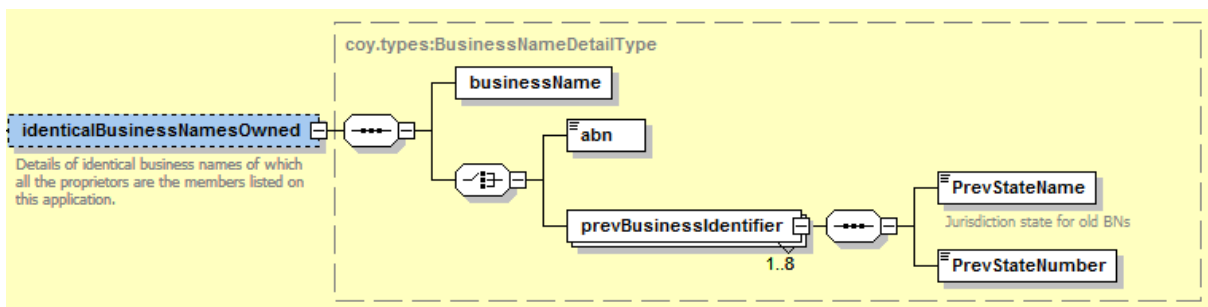
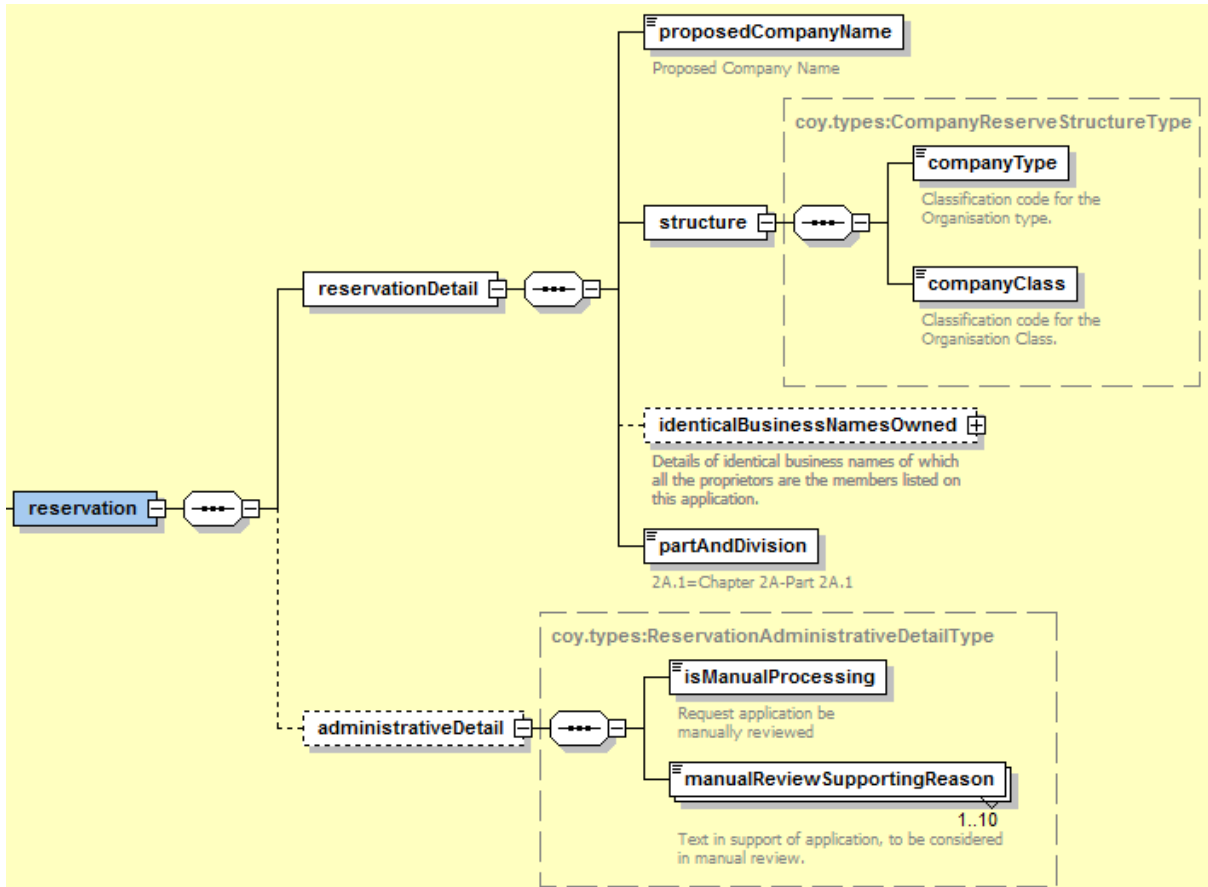
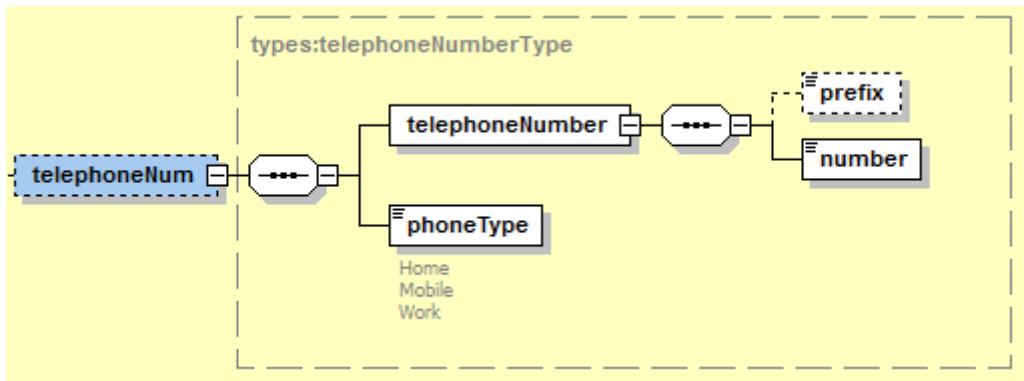

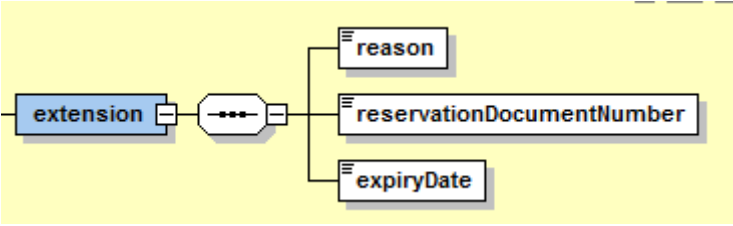

Message Content Table

Seq. No	XML Element	Type	Description	Business Rules/Instructions
1	applicantDetail	Complex content	Details of the company name reservation applicant	Mandatory
1.1	applicantName	Complex content	The person or organisation name of the applicant.	Mandatory
1.1.1	organisationDetail	Complex content	Container for the name of the company who applied for the company name reservation	Optional Must provide person or organisation name Not required if the applicant is a natural person
1.1.1.1	name	xs:string	Name of the organisation	Mandatory Maximum length 200 characters If ACN/ARBN provided, the name must match the organisation name as per ASIC records
1.1.1.2	acn	types:nniNumberType	ACN/ARBN of the company	Optional Must comply with the ACN algorithm – refer to Appendix D Must belong to a company that exists in ASIC register
1.1.2	personDetail	types:personNameType	Container for the name of the individual who applied for the company name reservation	Optional Must provide person or organisation name Not required if the applicant is an organisation
1.1.2.1	givenNames	xs:string	Given name of the applicant	Mandatory Minimum length 1 characters Maximum length 140 characters
1.1.2.2	otherGivenNames	xs:string	Other given names of the applicant	Optional Minimum length 1 characters Maximum length 140 characters

1.1.2.3	familyName	xs:string	Family name of the applicant	Mandatory Minimum length 2 characters Maximum length 40 characters
1.2	contact	Complex content	Contact details of the applicant. This includes physical address, telephone number & email address	Mandatory This information will be publically available on the document
1.2.1	address	Complex content	Contact address details of the applicant.	Must be a valid address
1.2.1.1	type	types:addressType	Not relevant for this message	Not used
1.2.1.2	careOf	xs:string	Care Of	Optional Maximum length 60 characters
1.2.1.3	country	xs:string	Country name as per Appendix C	Optional. If not provided it will be defaulted to "Australia"
1.2.1.4	startDate	xs:date	The date that this address started being used	Not used
1.2.1.5	DPID	xs:string	Post Office Delivery Point Identifier	Optional Maximum length 8 characters
1.2.1.6	physicalAddress	Complex content	Contains the data elements required for the Australian addresses	Conditional Either a physical; unstructured or semi structured physical address must be provided.
1.2.1.6.1	floorNumber	xs:string	The level of the building	Optional Maximum length 20 characters
1.2.1.6.2	propertyName	xs:string	The name of the property	Optional Maximum length 75 characters

1.2.1.6.3	unitOrOfficeNumber	xs:string	The unit number	Optional Maximum length 20 characters
1.2.1.6.4	streetNumber	xs:string	The street number	Optional Maximum length 20 characters
1.2.1.6.5	streetName	xs:string	Street name	Optional Maximum length 75 characters
1.2.1.6.6	streetType	xs:string	Street type	Must be a valid type - the list of valid values is available in Appendix C – LIST OF Values
1.2.1.6.7	postalDeliveryType	xs:string	The postal delivery type (e.g. PO Box, Locked Bag, etc)	Optional Must be a valid type – the list of values is available in Appendix C – List of Values
1.2.1.6.8	postalDeliveryNumber	xs:string	The number associated with the postal delivery type	Defined in schema as Optional. This element is mandatory for only certain postalDeliveryType enumerations Refer to Appendix C for list of postalDeliveryTypes that require a postalDeliveryNumber
1.2.1.6.9	locality	xs:string	Locality or suburb	Mandatory Maximum length 75 characters Must be formatted in title case (ex: North Sydney)
1.2.1.6.10	state	types:stateTerritoryCodeType	Australian state code	Mandatory, valid values are: ACT; NSW; NT; QLD; SA; TAS; VIC; WA;
1.2.1.6.11	postcode	xs:string	Australian postcode	Mandatory Maximum length 12 characters
1.2.1.7	unstructuredAddress	Complex content	Contains the data elements required for a foreign address	Conditional

1.2.1.7.1	addressLine1	xs:string	unstructured address line 1	Mandatory Maximum length 60 characters Enter address starting on line 1.
1.2.1.7.2	addressLine2	xs:string	unstructured address line 2	Mandatory Maximum length 60 characters
1.2.1.7.3	addressLine3	xs:string	unstructured address line 3	Optional Maximum length 60 characters
1.2.1.7.4	addressLine4	xs:string	unstructured address line 4	Optional Maximum length 60 characters
1.2.1.8	semiStructuredPhysicalAddress	Complex content	Contains the data elements required for an Australian address	Either a physical; unstructured or semi structured physical address must be provided.
1.2.1.8.1	addressLine1	xs:string	Semi structured address line	Mandatory Maximum length 60 characters Enter an Australian address not including locality, State/Territory and post code.
1.2.1.8.2	addressLine2	xs:string	Semi structured address line	Optional Maximum length 60 characters
1.2.1.8.3	locality	xs:string	Locality or suburb	Mandatory Maximum length 75 characters Must be formatted in title case (ex: North Sydney)
1.2.1.8.4	state	types:stateTerritoryCodeType	Australian state code	Mandatory, valid values are: ACT; NSW; NT; QLD; SA; TAS; VIC; WA
1.2.1.8.5	postCode	xs:string	Australian postcode	Mandatory Maximum length 12 characters

1.2.2	telephoneNum	types:telephoneNumberType	Telephone contact details	Optional
1.2.2.1	telephoneNumber	Complex content	Contact telephone number	Mandatory
1.2.2.1.1	prefix	xs:string	Telephone number prefix, eg country code or area code	Optional
1.2.2.1.2	number	xs:string	Telephone number	Mandatory Telephone number
1.2.2.2	phoneType	xs:string	Telephone number type	Mandatory Valid values: - Home - Mobile - Work
1.2.3	emailAddress	types:emailType	Contact email address.	Mandatory Minimum length 1 characters Maximum length 200 characters This will be used as the preferred address for correspondence related to this lodgement
2	reservation	Complex content	Details of the company reservation	Conditional Either the reservation or the extension elements must be completed.
2.1	reservationDetail	Complex content	Details of the company name reservation	Mandatory

2.1.1	proposedCompany Name	xs:string	The proposed company name	<p>Mandatory</p> <p>Maximum length 200 characters.</p> <p>Refer to Appendix E for legal elements</p> <p>Must contain valid characters:</p> <p>A to Z</p> <p>0 to 9</p> <p>! @ # \$ % ^ & * " () ? ; :</p> <p>= _ - / \ . , ' { } </p> <p>The proposed name in the lodgement must match the proposed name in the initiate payment request.</p>
2.1.2	structure	Complex content	The name, type & class of the proposed company	Mandatory
2.1.2.1	companyType	xs:string	The company type, either proprietary or public	<p>Mandatory</p> <p>Valid company types are:</p> <ul style="list-style-type: none"> • APTY Australian proprietary companies • APUB Australian public companies <p>Company type must match the company type in the initiate payment request.</p> <p>See appendix E for details of valid type/class/subclass combinations.</p>
2.1.2.2	companyClass	xs:string	The company class indicates how the company is structured	<p>Mandatory</p> <p>Valid company classes are:</p> <ul style="list-style-type: none"> • LMG T Limited by guarantee • LMS H Limited by shares • NLIA No liability <p>Company class must match the company class in the initiate payment request.</p> <p>See appendix E for details of valid type/class/subclass combinations.</p>

2.1.3	identicalBusinessNamesOwned	Complex content	Details of the business names that are identical to the company name being registered	Optional The identical business name details must match the details provided in the initiate payment requests. If the business name proprietor is a trust a signed copy of the trust deed must to be provided to ASIC. An attachment needs to be emailed to the following mailbox: Production mailbox – ecr.support@asic.gov.au Test mailbox – sbrp.test@asic.gov.au
2.1.3.1	businessName	types:nniNameType	Contains the details of the identical business name(s)	Mandatory Maximum length 200 characters.
2.1.3.2	abn	types: abnType	The ABN of the holder of the business name	Optional Length 11 characters If provided you must exist on ASIC BN register. Not required if the previous business identifier is provided
2.1.3.3	prevBusinessIdentifier	Complex content	Container for previous registration details for business names (before referral of powers to ASIC)	Not required if the ABN is provided Element may be repeated up to 8 times, one for each state
2.1.3.3.1	prevStateName	types:stateTerritoryCodeType	The state in which the BN was previously registered.	Mandatory Must be one of the following values: ACT; NSW; NT; QLD; SA; TAS; VIC; WA
2.1.3.3.2	prevStateNumber	xs:string	The number assigned by the state for registration of the business name	Mandatory Maximum of 10 characters
2.1.4	partAndDivision	xs:string	Indicates which section of the Corporations Act 2001 the proposed company will be registered under.	Mandatory Valid code values: - 2A.1 - Chapter 2A-Part 2A.1

2.2	administrativeDetail	Complex content	Request for manual review and providing information in support of this application	<p>Optional</p> <p>Manual determination will be required if:</p> <ul style="list-style-type: none"> - ASIC consent is required to use the proposed company name; - Ministerial consent is required; - Query name availability on the proposed company name returns a rejected name result and the applicant wish to proceed with the name; - The proposed name is identical to a business name that is not registered under an ABN entity holder. <p>If the customer has ministerial consent has to use the name, they must supply evidence to ASIC. An attachment needs to be emailed to the following mailbox: Production mailbox – ecr.support@asic.gov.au Test mailbox – sbrp.test@asic.gov.au</p>
2.2.1	isManualProcessing	xs:boolean	Request application be manually reviewed	<p>Mandatory</p> <p>Set value to 'true'</p> <p>The manual determination flag should be set the same as the initiate payment request.</p>
2.2.2	manualReviewSupportingReason	String	Text in support of application to be considered in manual review	<p>Mandatory</p> <p>Maximum length 80 characters</p> <p>Maximum occurrence = 10</p> <p>Must be completed if manual review is requested</p>
3	extension	Complex content	Details of an extension to an existing company name reservation	<p>Conditional</p> <p>Only one extension should be provided. Through this service each new reservation can only be extended once, every extension thereafter will not be accepted.</p>
3.1	reason	xs:string	The reason for the extension	<p>Mandatory</p> <p>Minimum length 1 characters</p> <p>Maximum of 200 characters.</p>

3.2	reservationDocumentNumber	xs:string	The document number of the previous name reservation application	Mandatory Maximum of 9 characters. Must match to a current reservation document The reservation document number must be the same as advised during initiate payment.
3.3	expiryDate	xs:date	The expiry date of the previous name reservation application	Mandatory Reservation must not be expired
4	signature	Complex content	Declaration from the applicant or his authorised person confirming all information provided is true & correct.	Mandatory
4.1	name	Complex content	Signatory name details	Mandatory
4.1.1	givenNames	xs:string	Given name of the individual	Mandatory Minimum length 1 characters Maximum length 140 characters
4.1.2	otherGivenNames	xs:string	Other given names	Optional Minimum length 1 characters Maximum length 140 characters
4.1.3	familyName	xs:string	Family name of the individual	Mandatory Minimum length 2 characters Maximum length 40 characters
4.2	capacity	Complex content	The role the signatory holds in the organisation if the applicant is an organisation	Conditional Must be completed if the applicant is an organisation Valid values are: DIR - Director SEC - Secretary AGT – Agent

4.3	dateSigned	xs:date	Signature date	Mandatory Must not be a future date The date signed must not be more than 6 months in the past.
4.4	declaresTrueAndCorrect	xs:boolean	The applicant view and assent to the declarations as detailed at Section 3.3	Mandatory The applicant view and assent to the declarations as detailed at Section 3.3

9.8.4. reservationLodgement Reply Message

Business Document Header

The WIG provides the standard specification of the Business Document Header. The following table specifies the message level specific data element values or any variations to the WIG.

Element Name	Instructions / Rules
asicTransactionNumber	Mandatory – transaction unique identifier assigned by ASIC for this transaction

Business Document Body

The 'businessDocumentBody' segment will be returned for new reservation request only and if no errors are found in the message.

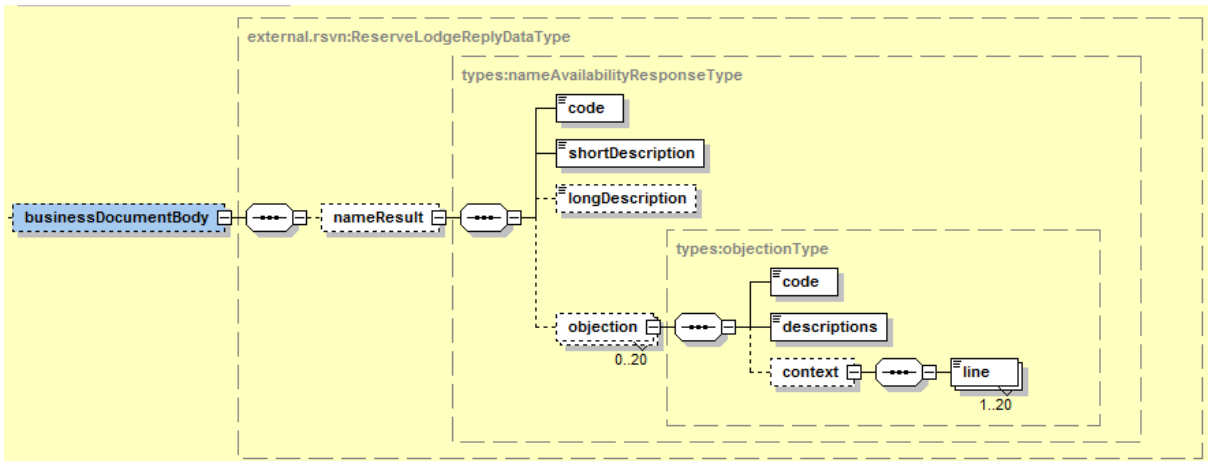

Message Content Table

Seq. No	XML Element	Type	Description
1	nameResult	Complex content	Indicates the result of the name assessment for the proposed company name upon submitting the application. This validation is same as the validation done using the queryNameAvailability service.
1.1	code	xs:string	Will return one of the following valid values : Available –the name is available to be used for a company Unavailable –the name can't be used and the user should propose another name

			<p>SubjectToNamesDetermination –the name is referred to ASIC staff for manual determination</p> <p>Identical – meaning the name is identical to another name and it may be rejected or referred to manual determination</p>
1.2	shortDescription	xs:string	A short text description associated with the code (as listed above) and it provides the result of the name availability check done as part of the validations for the application being submitted
1.3	longDescription	xs:string	A long text description associated with the codes (as listed above) and it provides the result of the name availability check done as part of the validations for the application being submitted
1.4	objections	Complex content	Returned only when the proposed name is unavailable or it is subject to name determination. It contains a code and a description and indicates the reason for the decision.
1.4.1	code	xs:string	The code used by ASIC for the objections. It is returned only if the name is unavailable or is referred to manual processing. Refer to appendix E for some examples of likely name availability objection codes. Please note that is best to develop a generic process to display the code and description as opposed to hard coding these. ASIC may in time choose to tweak or embellish upon the objection descriptions.
1.4.2	description	xs:string	The description associated with the code of the objections.
1.4.3	context	complexType	Additional information returned when the name is identical or near identical to another existing name.
1.4.3.1	line	xs:string	Contains the ASIC internal identifier for a business name or Australian Company Number and the company name that resulted in the exact match (i.e. the existing registered name).

9.9. MESSAGE SPECIFICATION - `getTransactionStatus`

9.9.1. Business Overview

This message is used to return the details of a transaction that has been submitted to ASIC.

It would typically be called by the user in one of the following scenarios:

- An "Initiate Payment" request has been successfully submitted to ASIC, and the user wants to ascertain the status of the payment.
- One or more of the applications has returned a pending status, and the client wishes to determine if the transaction has been completed (eg, if a proposed name had to be manually determined, this service will return the name determination result).
- If lodgement response details had been lost and needed to be resupplied (eg, the company certificate URL)

The interface returns details of a transaction previously submitted to ASIC. It may be necessary to submit more than one `getTransactionStatus` message in order to retrieve all the details of a transaction.

The client will supply one of two transaction identifiers:

- The Transaction Reference Number, which will return details of all transactions submitted using that TRN.
- The ASIC Transaction Number, which will return details of the specific company, reservation or business name lodgement associated with that transaction number.

The interface will validate the supplied transaction identifier and retrieve details of the transaction and associated payment (if any).

9.9.2. HTTPS Connections & WSDL

The requestor's code must establish a HTTPS connection to the appropriate endpoint using the standard port 443.

Environment	WSDL
Production	https://www.gateway.asic.gov.au/gateway/ExternalGetTransactionStatusPort?WSDL
Test	https://www.gateway.uat.asic.gov.au/gateway/ExternalGetTransactionStatusPort?WSDL

9.9.3. *getTransactionStatus Request Message*

Business Document Header

The WIG provides the specification of the Business Document Header. The following table specifies the message specific data element values or any variations to the WIG.

Element Name	Instructions / Rules	Error code
MessageType	Mandatory, value must be getTransactionStatus	00002
MessageVersion	Mandatory , value must be 1	00004
senderType	Mandatory, value must be REGA	00005
senderId	The identifier assigned by ASIC on registration	00005

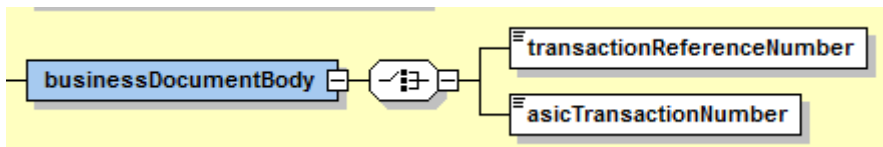

Message Content Table

Seq. No	XML Element	Type	Description	Business Rules/Instructions
1	transactionReferenceNumber	xs:string	The reference number supplied by the client in previous lodgements of InitiatePayment, company registration, company reservation and business name registration lodgements	Optional – only transactionReferenceNumber or ASICTransactionNumber may be provided. If entered, it will return the transaction and payment status including details of all lodgement status using this identifier Maximum length 64 characters
2	ASICTransactionNumber	xs:string	The ASIC transaction number returned from a previous lodgement of a company registration, company reservation or business name registration application	Optional – only transactionReferenceNumber or ASICTransactionNumber may be provided. If entered, it will return details of the one lodgement associated with this identifier. Maximum length 64 characters

9.9.4. getTransactionStatus Reply Message

Business Document Body

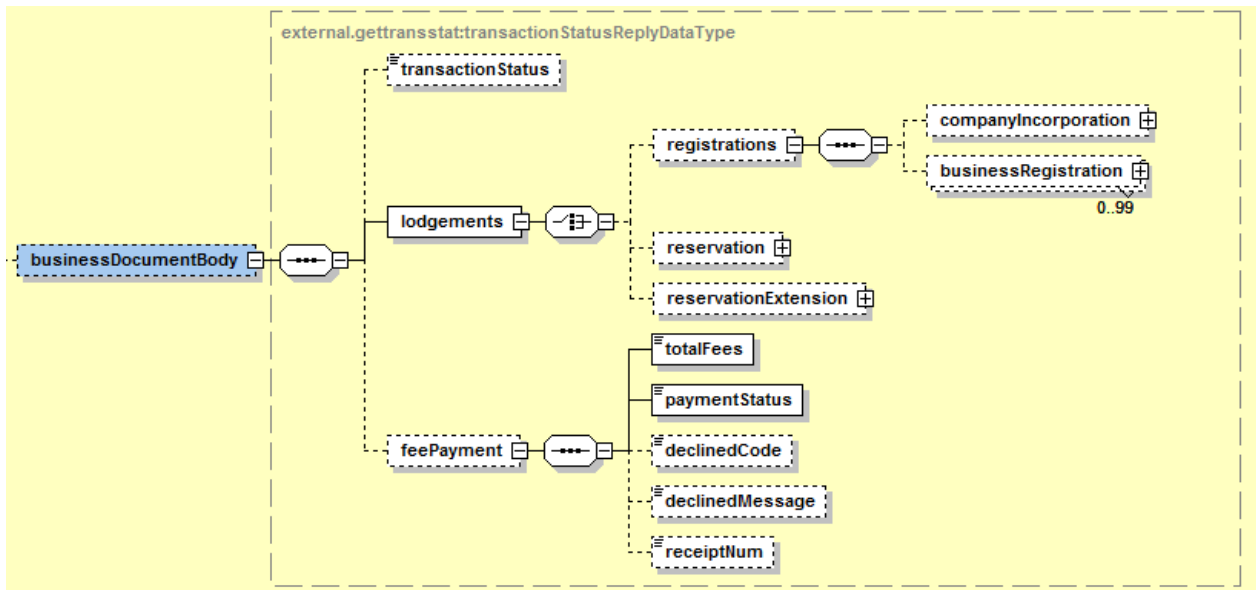

Lodgements Details

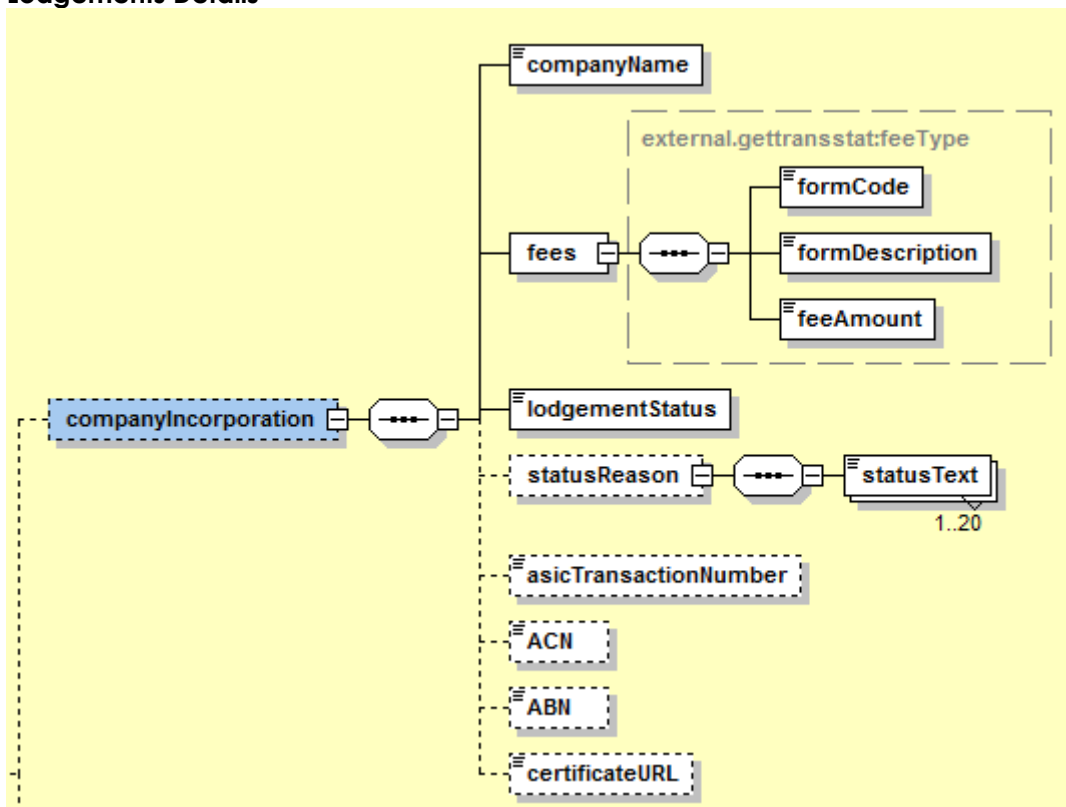

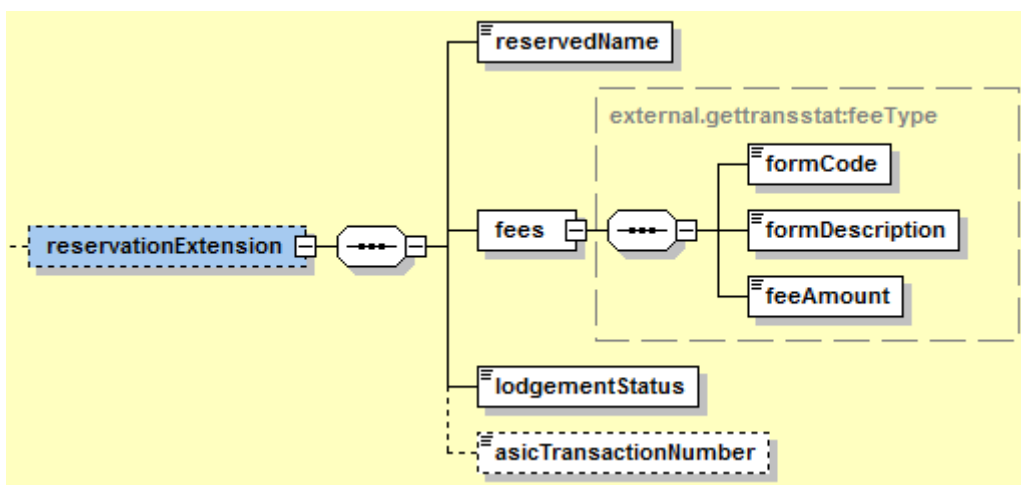
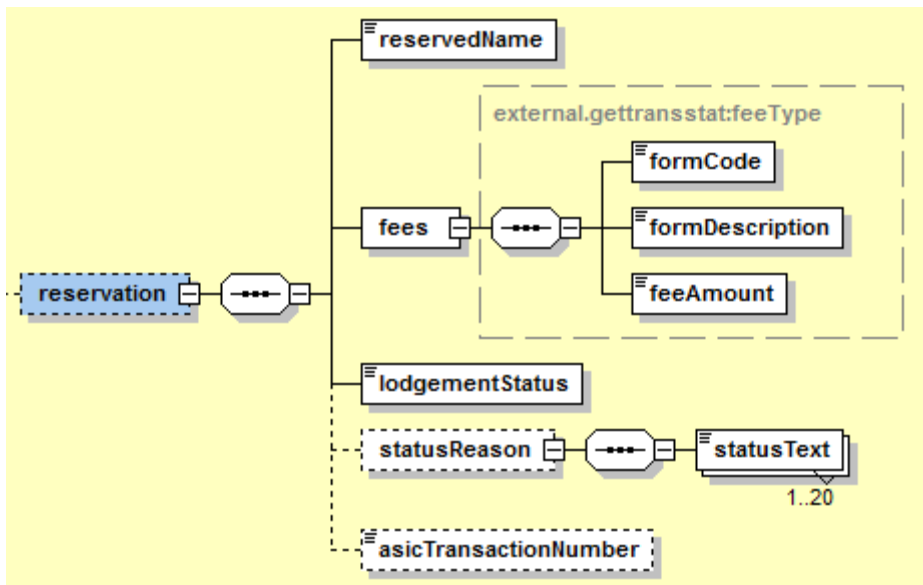
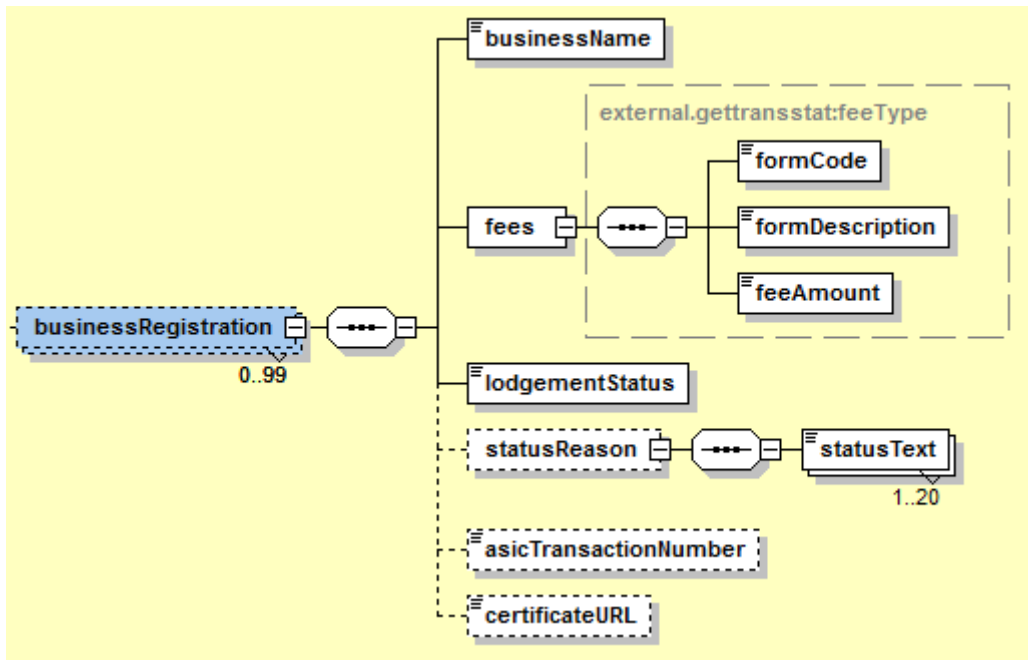

Message Content Table

Seq. No	XML Element	Type	Description
1	transactionStatus	xs:string	The current status of the entire transaction. This value will only be returned when the request is made by the transactionReferenceNumber. Possible values: <ul style="list-style-type: none"> - CREATED (no transactions submitted) - INPROGRESS (transactions received, one or more incomplete) - COMPLETE (all transactions complete)
2	lodgements	Complex content	Contains details of each lodgement in relation to the supplied request parameter.
2.1	registrations	Complex content	Details of company or business name registrations
2.1.1	companyIncorporation	Complex content	Details of the company incorporation transaction.
2.1.1.1	companyName	types:nniNameType	The company name being registered Maximum 200 characters
2.1.1.2	fees	Complex content	Fee details of the company registration transaction.
2.1.1.2.1	formCode	xs:string	The ASIC form code for this transaction Maximum length 5 characters
2.1.1.2.2	formDescription	xs:string	The ASIC form description for this transaction Maximum length 80 characters
2.1.1.2.3	feeAmount	xs:decimal	The assessed fee for this transaction
2.1.1.3	lodgementStatus	xs:string	The status of this lodgement. Values are: <ul style="list-style-type: none"> - NOTR (not received) - CANC (lodgement cancelled) - ERR (System error occurred during processing) - INPR (In progress) - MANL (name requires manual determination) - REJT (name rejected) - COMP (approved)
2.1.1.4	statusReason	Complex content	

2.1.1.4.1	statusText	xs:string	Text relating to the current lodgementStatus: <ul style="list-style-type: none"> - If lodgementStatus is "MANL", the reason/s the name was queued - If lodgementStatus is "REJT", the reason/s the name was rejected. Maximum length 2000 characters
2.1.1.5	asicTransactionNumber	xs:string	The ASIC transaction number assigned to the lodgement. Not returned if lodgementStatus is "NOTR" Maximum length 64 characters
2.1.1.6	ACN	types:nniNumberType	The allocated ACN. Only returned if lodgementStatus is "COMP".
2.1.1.7	ABN	types:abnType	Not returned, reserved for future use
2.1.1.8	certificateURL	xs:string	The URL from where the company certificate can be retrieved. Only returned if lodgementStatus is "COMP". Maximum length 512 characters
2.1.2	businessRegistration	Complex content	Details of the business name registration transactions.
2.1.2.1	businessName	types:nniNameType	The business name being registered Maximum 200 characters
2.1.2.2	fees	Complex content	Fee details of the business name registration transaction.
2.1.2.2.1	formCode	xs:string	The ASIC form code for this transaction Maximum length 5 characters
2.1.2.2.2	feeDescription	xs:string	The ASIC form description for this transaction Maximum length 80 characters
2.1.2.2.3	formAmount	xs:decimal	The assessed fee for this transaction
2.1.2.3	lodgementStatus	xs:string	The status of this lodgement. Values are: <ul style="list-style-type: none"> - NOTR (not received) - CANC (lodgement cancelled) - ERR (System error occurred during processing) - INPR (In progress) - MANL (name requires manual determination) - RFSD (business name registration where ASIC staff have made a determination) - REJT (name rejected) - COMP (complete)

2.1.2.4	statusReason	Complex content	
2.1.2.4.1	statusText	xs:string	Text relating to the current lodgementStatus: <ul style="list-style-type: none"> - If LodgementStatus is "MANL", the reason/s the name was queued - If lodgementStatus is "REJT", the reason/s the name was rejected. Maximum length 2000 characters
2.1.2.5	asicTransactionNumber	xs:string	The ASIC transaction number assigned to the lodgement. Not returned if lodgementStatus is "NOTR" Maximum length 64 characters
2.1.2.6	certificateURL	xs:string	The URL from where the business name certificate can be retrieved. Only returned if lodgementStatus is "COMP". Maximum length 512 characters
2.2	reservation	Complex content	Details of the reservation transaction.
2.2.1	reservedName	types:nniNameType	The company name being registered Maximum 200 characters
2.2.2	fees	Complex content	Fee details of the reservation transaction.
2.2.2.1	formCode	xs:string	The ASIC form code for this transaction Maximum length 5 characters
2.2.2.2	formDescription	xs:string	The ASIC form description for this transaction Maximum length 80 characters
2.2.2.3	feeAmount	xs:decimal	The assessed fee for this transaction
2.2.3	lodgementStatus	xs:string	The status of this lodgement. Values are: <ul style="list-style-type: none"> - NOTR (not received) - CANC (lodgement cancelled) - ERR (System error occurred during processing) - INPR (In progress) - MANL (name requires manual determination) - REJT (name rejected) - COMP (complete)
2.2.4	statusReason	Complex content	
2.2.4.1	statusText	xs:string	Text relating to the current lodgementStatus:

			<ul style="list-style-type: none"> - If LodgementStatus is "MANL", the reason/s the name was queued - If lodgementStatus is "REJT", the reason/s the name was rejected. <p>Maximum length 2000 characters</p>
2.2.5	asicTransactionNumber	xs:string	<p>The ASIC transaction number assigned to the lodgement. Not returned if lodgementStatus is "NOTR"</p> <p>Maximum length 64 characters</p>
2.3	reservationExtension	Complex content	<p>Details of the reservation extension transaction.</p>
2.3.1	reservedName	types:nniNameType	<p>The company name being registered</p> <p>Maximum 200 characters</p>
2.3.2	fees	Complex content	<p>Fee details of the reservation extension transaction.</p>
2.3.2.1	formCode	xs:string	<p>The ASIC form code for this transaction</p> <p>Maximum length 5 characters</p>
2.3.2.2	formDescription	xs:string	<p>The ASIC form description for this transaction</p> <p>Maximum length 80 characters</p>
2.3.2.3	feeAmount	xs:decimal	<p>The assessed fee for this transaction</p>
2.3.3	lodgementStatus	xs:string	<p>The status of this lodgement. Values are:</p> <ul style="list-style-type: none"> - NOTR (not received) - CANC (lodgement cancelled) - ERR (System error occurred during processing) - INPR (In progress) - MANL (extension requires manual determination) - REJT (extension rejected) - COMP (complete)
2.3.5	asicTransactionNumber	xs:string	<p>The ASIC transaction number assigned to the lodgement. Not returned if lodgementStatus is "NOTR"</p> <p>Maximum length 64 characters</p>
3	feePayment	Complex content	
3.1	totalFees	xs:decimal	<p>The total fees for all lodgements</p>
3.2	paymentStatus	xs:string	<p>Valid value are:</p> <ul style="list-style-type: none"> - PAID (payment is complete) - UNPAID (payment has been initiated) - CANCELLED (payment cancelled by user)

			- DECLINED (payment declined by bank)
3.3	declinedCode	xs:string	If paymentStatus is "DECLINED", this contains the declined code. Maximum length 32 characters
3.4	declinedMessage	xs:string	If paymentStatus is "DECLINED", this contains the declined message. Maximum length 128 characters
3.5	receiptNum	xs:string	If paymentStatus is "PAID", this contains the receipt number. Maximum length 32 characters

APPENDIX A – MAPPING ABR ENTITY TYPES TO ASIC ENTITY TYPES

ASIC business entity	ABR entity type
Incorporated body	PRV – Australian Private Company PUB – Australian Public Company CCR - Australian Private Company – Commonwealth LCR - Australian Private Company – Local SCR - Australian Private Company – State TCR - Australian Private Company – Territory CCB - Australian Public Company – Commonwealth LCB - Australian Public Company – Local SCB - Australian Public Company – State TCB - Australian Public Company – Territory PDF - Pooled Development Fund CCP - Pooled Development Fund – Commonwealth LCP - Pooled Development Fund – Local SCP - Pooled Development Fund – State TCP - Pooled Development Fund – Territory
Individual	IND – Individual
Partnership	FPT – Family Partnership LPT – Limited Partnership PTR – Other Partnership LCL - Limited Partnership – Local SCL - Limited Partnership – State TCL - Limited Partnership – Territory CGP - Other Partnership – Commonwealth LGP - Other Partnership – Local SGP - Other Partnership – State TGP - Other Partnership – Territory
Unincorporated entity	All other types such as: ADF – Approved Deposit Fund ARF – APRA Regulated Fund (Fund Type Unknown) CCC - Co-operative – Commonwealth CCN - Other Unincorporated Entity – Commonwealth CCU - Corporate Unit Trust – Commonwealth CGA - Commonwealth Government Statutory Authority CGC - Commonwealth Government Company CGE - Commonwealth Government Entity CGS - Commonwealth Government Superannuation Fund CGT - Commonwealth Government Trust CMT – Cash Management Trust COP – Co-operative

ASIC business entity	ABR entity type
	CSA - APRA-Regulated Super Fund -Commonwealth - Public Sector Fund CSP - APRA-Regulated Super Fund - Commonwealth - Public Sector Scheme CSS - A Non-Regulated Superannuation Fund – Commonwealth CTC - Cash Management Trust – Commonwealth CTD - Discretionary Trust - Services Management – Commonwealth CTF - Fixed Trust – Commonwealth CTH - Hybrid Trust – Commonwealth CTI - Discretionary Trust - Investment – Commonwealth CTL - Public Unit Trust - Listed – Commonwealth CTQ - Public Unit Trust - Unlisted – Commonwealth CTT - Discretionary Trust - Trading – Commonwealth CTU - Fixed Unit Trust - Commonwealth CUT – Corporate Unit Trust DES – Deceased Estate DIP – Diplomatic Consulate Body or High Commissioner DIT – Discretionary Investment Trust DST – Discretionary Service Management Trust DTT – Discretionary Trading Trust FHS – First Home Saver Account (FHSA) Trust FUT – Fixed Unit Trust FXT – Fixed Trust HYT – Hybrid Trust LCC - Co-operative – Local LCN – Other Unincorporated Entity - Local LCU - Corporate Unit Trust – Local LGA - Local Government Statutory Authority LGC - Local Government Company LGE - Local Government Entity LGT - Local Government Trust LSA - APRA-Regulated Super Fund - Local - Public Sector Fund LSP - APRA-Regulated Super Fund - Local - Public Sector Scheme LSS - A Non-Regulated Superannuation Fund – Local LTC - Cash Management Trust – Local LTD - Discretionary Trust - Services Management – Local LTF - Fixed Trust – Local LTH - Hybrid Trust – Local LTI - Discretionary Trust - Investment – Local LTL - Public Unit Trust - Listed – Local

ASIC business entity	ABR entity type
	LTQ - Public Unit Trust - Unlisted – Local LTT - Discretionary Trust - Trading – Local LTU - Fixed Unit Trust - Local NPF – APRA Regulated Non-Public Offer Fund NRF – Non-Regulated Superannuation Fund POF – APRA Regulated Public Offer Fund PQT – Unlisted Public Unit Trust PST – Pooled Superannuation Trust PUT – Listed Public Unit Trust SAF – Small APRA Regulated Fund SCC - Co-operative – State SCN - Other Unincorporated Entity – State SCU - Corporate Unit Trust – State SGA - State Government Statutory Authority SGC - State Government Company SGE - State Government Entity SGT - State Government Trust SMF – An ATO Regulated Self-Managed Superannuation Fund SSA - APRA-Regulated Super Fund - State - Public Sector Fund SSP - APRA-Regulated Super Fund - State - Public Sector Scheme SSS - A Non-Regulated Superannuation Fund – State STC - Cash Management Trust – State STD - Discretionary Trust - Services Management – State STF - Fixed Trust – State STH - Hybrid Trust – State STI - Discretionary Trust - Investment – State STL - Public Unit Trust - Listed – State STQ - Public Unit Trust - Unlisted – State STT - Discretionary Trust - Trading – State STU - Fixed Unit Trust – State SUP - Super Fund TCC - Co-operative – Territory TCN - Other Unincorporated Entity – Territory TCU - Corporate Unit Trust – Territory TGA - Territory Government Statutory Authority TGE - Territory Government Entity TGT - Territory Government Trust TRT - Other Trust TSA - APRA-Regulated Super Fund - Territory - Public Sector Fund TSP - APRA-Regulated Super Fund - Territory - Public Sector Scheme

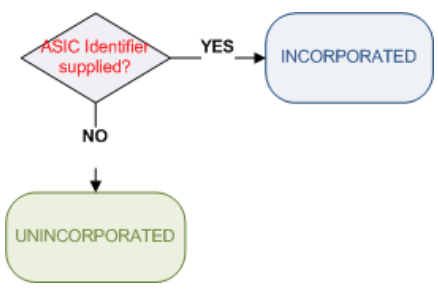
ASIC business entity	ABR entity type
	TSS - A Non-Regulated Superannuation Fund – Territory TTC - Cash Management Trust – Territory TTD - Discretionary Trust - Services Management – Territory TTF - Fixed Trust – Territory TTH - Hybrid Trust – Territory TTI - Discretionary Trust - Investment – Territory TTL - Public Unit Trust - Listed – Territory TTQ – Public Unit Trust - Unlisted – Territory TTT - Discretionary Trust - Trading – Territory TTU - Fixed Unit Trust - Territory UIE - Other Unincorporated Entity
<p>Incorporated body/ Unincorporated entity</p> <p>The entities in this category may in some cases be registered with ASIC and therefore able to supply an ACN or ARBN.</p>  <pre> graph TD A{ASIC Identifier supplied?} -- YES --> B(INCORPORATED) A -- NO --> C(UNINCORPORATED) </pre> <p>If the entity supplies an ACN or ARBN we will treat them as 'Incorporated body'.</p> <p>If the entity can't provide an ACN/ARBN we will treat them as 'Unincorporated' entities.</p>	OIE – Other Incorporated Entity CCO - Other Incorporated Entity – Commonwealth LCO - Other Incorporated Entity – Local SCO - Other Incorporated Entity – State TCO - Other Incorporated Entity – Territory CCS - Strata-title – Commonwealth CCT - Public Trading Trust – Commonwealth LCS - Strata-title – Local LCT - Public Trading Trust – Local PTT – Public Trading Trust SCS - Strata-title – State SCT - Public Trading Trust – State STR – Strata-title TCS - Strata-title – Territory TCT - Public Trading Trust – Territory
Joint venture	N/A Comment: Joint ventures that are not incorporated with ABR and do not have an ABN must supply the ABN for each participant
Christmas Island and Cocos Islands entities	N/A Comment: These must be businesses run entirely in those territories only and that are not eligible for an ABN.

APPENDIX B - RENEWAL DATE ALIGNMENT

If the business holder owns another business name(s) or the holder is a company then the user is presented with options to align the renewal date of the in progress application with one of the renewal dates for the other business name(s) or with the company's review date.

As per the legislation, alignment to alternative dates is only allowed under certain conditions.

The alternative registration dates are presented only if they match the following rules:

a) 1 year registration - of no more than 18 months and no less than 3 months from application date

and

(b) 3 year registration - of no more than 3 years and 6 months and no less than 18 months from application date.

Example

Assume a company completes an online application to register a new business name **@01/06/2012**.

Application date = 01/06/2012

Company review date = 28/07/2012 (provided by ASIC in ASIC service)

Step 1: Calculate next three subsequent review dates (to cover up to 3 year renewal period) from review date provided:

28/07/12; 28/07/2013; 28/07/2014; 28/07/2015

Step 2: Calculate allowable date ranges for 1 and 3 year registration options:

One year registration date range :

Start date = 'Application date' + 3 months = 01/09/2012

End date = 'Application date'+18 months= 01/12/2013

Three year registration date range:

Start date = 'Application date' + 18 months + 1 day =02/12/2013

End date = 'Application date'+3 years + 6 months= 30/11/2015

Step 3: Determine if company review dates fall within permissible range for renewal alignment

FOR each review date calculated in Step 1

IF review date >= one_year_start_date_range AND review date <= one_year_end_date_range THEN

Display as option for alignment under 1 year registration period

ELSE

Do not display under 1 year registration period

IF review date >= three_year_start_date_range AND review date <= three_year_end_date_range THEN

Display as option for alignment under 3 year registration period

ELSE

Do not display under 3 year registration period

NEXT

Results of the above pseudo algorithm should yield:

28/07/2012 NO 1 year, NO 3 year

28/07/2013 YES 1 year, NO 3 year

28/07/2014 NO 1 year, YES 3 years

28/07/2015 NO 1 year, YES 3 years

APPENDIX C – LIST OF VALUES

Organisation types	
Code	Description
APTY	Australian Proprietary Company
APUB	Australian Public Company
ARPA	Australian Passport Fund
ARPF	Foreign Passport Fund
ASSN	Association
BUSN	Business Name
CHAR	Charity
COMP	Community Purpose
COOP	Co-Operative Society
LTDP	Limited Partnership
MISM	Managed Investment Scheme
NONC	Non Company
NRET	Non Registered Entity
RACN	Registered Australian Body
REBD	Religious Body
RSVN	Name Reservation
SOLS	Solicitor Corporation
TRST	Trust

Address types	
Code	Description
RG	Registered office (Company)
RP	Registered office (foreign company)
PA	Principal Place of Business Address (Company)
RO	Registered Office in place of incorporation (foreign company)
GC	Residential address (business names)
GD	Address for the place of business (business names)
GE	Address for the service of documents (business names)
GL	Contact Address (business names)

Status types (values depend on the entity type)	
Code	Description
PEND	Pending registration
REGD	Registered
DRGD	Deregistered
HELD	Held
SOFF	Strike-off
EXAD	Under External Administration and/or Controller Appointed
CNCL	Cancelled
NRGD	Not registered

DMNT	Dormant
------	---------

Street types				
Code	Code	Code	Code	Code
Accs	Cres	Gdns	Pkwy	Spur
Ally	Cres E	Gld	Pl	Sq
Ambl	Cres N	Glen	Pl E	Sq E
App	Cres S	Gly	Pl N	Sq N
Arc	Cres W	Gr	Pl S	Sq S
Art	Crsg	Gr E	Pl W	Sq W
Ave	Crss	Gr N	Plza	St
Ave Cn	Crss W	Gr S	Pnt	St Cn
Ave E	Crst	Gra	Port	St E
Ave Ex	Cso	Grn	Prom	St Ex
Ave N	Ct	Gte	Qdrt	St N
Ave S	Ct E	Hill	Quad	St S
Ave W	Ct N	Hts	Qy	St W
Bch	Ct S	Hwy	Qy E	Stps
Bdwy	Ct W	Hwy E	Qy W	Strp
Bend	Ctr	Hwy N	Qys	Tarn
Brae	Cftg	Hwy S	Ramp	Tce
Brce	Ctyd	Hwy W	Rch	Tce E
Brk	Dale	Jnc	Rd	Tce Ex
Brow	Dell	Key	Rd Cn	Tce N
Bvd	Devn	Lane	Rd E	Tce S
Bvd E	Dr	Lane E	Rd Ex	Tce W
Bvd S	Dr E	Lane N	Rd Lr	Top
Bvd W	Dr N	Lane S	Rd N	Tor
Bypa	Dr S	Lane W	Rd S	Trk
Caus	Dr W	Line	Rd W	Trk E
Cct	Drwy	Link	Rdge	Trl
Cct E	Edge	Lkt	Rds	Turn
Cct W	Elb	Lnwy	Rdwy	Vale
Ch	End	Loop	Res	View
Cir	Ent	Mall	Rest	Vsta
Cir N	Esp	Mews	Ride	Walk
Cir S	Esp N	Mndr	Ring	Walk N
Cl	Esp S	Mwy	Rise	Walk S
Cl N	Est	Nook	Rmbl	Way
Cl S	Fawy	Otlk	Rnd	Way E
Clf	Fitr	Park	Rnge	Way N
Cmmn	Flat	Pass	Row	Way S
Cnr	Folw	Path	Rte	Way W
Con	Fnt	Pde	Rtt	Whrf
Cove	Frtg	Pde E	Run	Wkwy
Cps	Fshr	Pde N	Rvr	Wynd
Crcs	Ftrk	Pde S	SWy	
Crcs E	Fwy	Pde W	Sbwy	
Crcs W	Gap	Pkt	Slpe	

Postal delivery types	
Code	Description
CARE PO	Care of Post Office / Poste Restante
CMA	Community Mail Agent
CMB	Community Mail Bag
GPO BOX	General Post Office Box PostalDeliveryNumber is mandatory for this PostalDeliveryType
LOCKED BAG	Locked Mail Bag Service PostalDeliveryNumber is mandatory for this PostalDeliveryType
MS	Mail Service
PO BOX	Post Office Box PostalDeliveryNumber is mandatory for this PostalDeliveryType
PRIVATE BAG	Private Mail Bag Service PostalDeliveryNumber is mandatory for this PostalDeliveryType
RSD	Roadside Delivery
RMB	Roadside Mail Bag/Box PostalDeliveryNumber is mandatory for this PostalDeliveryType
RMS	Roadside Mail Service
CPA	Community Postal Agent

Country Descriptions		
Afghanistan	China	Guatemala
Aland Islands	Christmas Island	Guernsey
Albania	Cocos (Keeling) Islands	Guinea
Algeria	Colombia	Guinea-Bissau
American Samoa	Comoros	Guyana
Andorra	Congo	Haiti

Angola	Congo, the Democratic Republic of the	Heard Island and McDonald Islands
Anguilla	Cook Islands	Holy See (Vatican City State)
Antarctica	Costa Rica	Honduras
Antigua And Barbuda	Cote D'Ivoire	Hong Kong
Argentina	Croatia	Hungary
Armenia	Cuba	Iceland
Aruba	Curacao	India
Australia	Cyprus	Indonesia
Austria	Czech Republic	Iran, Islamic Republic Of
Azerbaijan	Denmark	Iraq
Bahamas	Djibouti	Ireland
Bahrain	Dominica	Isle Of Man
Bangladesh	Dominican Republic	Israel
Barbados	Ecuador	Italy
Belarus	Egypt	Jamaica
Belgium	El Salvador	Japan
Belize	Equatorial Guinea	Jersey
Benin	Eritrea	Jordan
Bermuda	Estonia	Kazakhstan
Bhutan	Ethiopia	Kenya
Bolivia	Falkland Islands (Malvinas)	Kiribati
Bonaire, Sint Eustatius and Saba	Faroe Islands	Korea, Democratic People's Republic of
Bosnia And Herzegovina	Fiji	Korea, Republic Of
Botswana	Finland	Kuwait
Bouvet Island	France	Kyrgyzstan

Brazil	French Guiana	Lao People's Democratic Republic
British Indian Ocean Territory	French Polynesia	Latvia
Brunei Darussalam	French Southern Territories	Lebanon
Bulgaria	Gabon	Lesotho
Burkina Faso	Gambia	Liberia
Burundi	Georgia	Libyan Arab Jamahiriya
Cambodia	Germany	Liechtenstein
Cameroon	Ghana	Lithuania
Canada	Gibraltar	Luxembourg
Cape Verde	Greece	Macao
Cayman Islands	Greenland	Macedonia
Central African Republic	Grenada	Madagascar
Chad	Guadeloupe	Malawi
Chile	Guam	Malaysia
Maldives	Romania	Turkmenistan
Mali	Russian Federation	Turks And Caicos Islands
Malta	Rwanda	Tuvalu
Marshall Islands	Saint Barthelemy	Uganda
Martinique	Saint Helena, Ascension and Tristan Da Cunha	Ukraine
Mauritania	Saint Kitts And Nevis	United Arab Emirates
Mauritius	Saint Lucia	United Kingdom
Mayotte	Saint Martin (French Part)	United States
Mexico	Saint Pierre And Miquelon	United States Minor Outlying Islands
Micronesia	Saint Vincent and the Grenadines	Uruguay
Moldova, Republic Of	Samoa	Uzbekistan

Monaco	San Marino	Vanuatu
Mongolia	Sao Tome And Principe	Venezuela, Bolivarian Republic
Montenegro	Saudi Arabia	Viet Nam
Montserrat	Senegal	Virgin Islands, British
Morocco	Serbia	Virgin Islands, U.S.
Mozambique	Seychelles	Wallis And Futuna
Myanmar	Sierra Leone	Western Sahara
Namibia	Singapore	Yemen
Nauru	Sint Maarten (Dutch Part)	Zambia
Nepal	Slovakia	Zimbabwe
Netherlands	Slovenia	Unknown
New Caledonia	Solomon Islands	Northern Ireland
New Zealand	Somalia	
Nicaragua	South Africa	
Niger	South Georgia and the South Sandwich Islands	
Nigeria	Spain	
Niue	Sri Lanka	
Norfolk Island	Sudan	
Northern Mariana Islands	Suriname	
Norway	Svalbard And Jan Mayen	
Oman	Swaziland	
Pakistan	Sweden	
Palau	Switzerland	
Palestinian Territory, OCC	Syrian Arab Republic	
Panama	Taiwan	
Papua New Guinea	Tajikistan	

Paraguay	Tanzania, United Republic Of
Peru	Thailand
Philippines	Timor-Leste
Pitcairn	Togo
Poland	Tokelau
Portugal	Tonga
Puerto Rico	Trinidad And Tobago
Qatar	Tunisia
Reunion	Turkey

APPENDIX D - ALGORITHMS

AUSTRALIAN COMPANY NUMBER

The ACN is a nine-digit number with the right most digit being a check digit calculated using a modified modulus 10 calculation.

ASIC has adopted a convention of always printing and displaying the ACN in the format nnn nnn nnn ie three blocks of three characters separated by a blank. This is to assist readability and the inserted blanks do not form part of the ACN.

To validate the check digit for ACN 004 085 616

- ◆ apply weighting to digits 1 to 8

digit	0	0	4	0	8	5	6	1
weight	8	7	6	5	4	3	2	1
digit * weight	0	0	24	0	32	15	12	1

- ◆ sum the products $0 + 0 + 24 + 0 + 32 + 15 + 12 + 1 = 84$
- ◆ divide by 10 to obtain remainder $84 / 10 = 8$ remainder 4
- ◆ complement the remainder to 10 $10 - 4 = 6$
(if complement = 10, set to 0)

Thus calculated check digit (6) equals actual check digit (6) so ACN 004 085 616 is VALID.

Note that Australian Registered Body Numbers (ARBNs) are constructed using the same formula.

AUSTRALIAN BUSINESS NUMBER

The ABN is an eleven-digit number with the two left most digits being check digits.

ASIC has adopted a convention of always printing and displaying the ABN in the format nn nnn nnn nnn ie one block of two characters followed by three blocks of three characters separated by a blank. This is to assist readability and the inserted blanks do not form part of the ABN.

To validate the check digit for ABN 53 004 085 616

- ◆ subtract 1 from the first number on the left, so 53 004 085 616 becomes 43 004 085 616

- ◆ apply weighting to each digit

digit	4	3	0	0	4	0	8	5	6	1	6
weight	10	1	3	5	7	9	11	13	15	17	19
digit * weight	40	3	0	0	28	0	88	65	90	17	114

- ◆ sum the products $40 + 3 + 0 + 0 + 28 + 0 + 88 + 65 + 90 + 114 = 445$
- ◆ in a valid ABN the sum of these products is a multiple of 89, so divide the sum by 89. If there is no remainder the ABN is valid
- ◆ $445 / 89 = 5$ with no remainder, so ABN 53 004 085 61 is VALID

APPENDIX E – COMPANY STRUCTURE AND NAMES

COMPANY TYPE, CLASS AND SUBCLASS

	LMSH	LMGT	NLIA
PNPC	APTY	-	-
PSTC	APTY	-	-
PROP	APTY	-	-
HUNT	APTY	-	-
ULSS	APUB	APUB	-
ULST	APUB	APUB	APUB
ULSN	APUB	APUB	-

This table indicates the company type that is valid for a particular combination of class and subclass when registering a new company.

A hyphen indicates that no company type is valid for the class/subclass combination.

LEGAL ELEMENTS

TYPE	CLASS	LEGAL ELEMENT 1	LEGAL ELEMENT 2	Business rule for Type and Class
APTY	LMSH	PTY PTY. PROPRIETARY	LTD LTD. LIMITED	Must have two legal elements. First element must be from Element 1 and second element must be from Element 2
APUB	LMSH	LTD LTD. LIMITED		
APUB	LMGT	LTD LTD. LIMITED		
APUB	NLIA	NL N.L. NO LIABILITY		Can only have one legal element

STANDARD SHARE CLASSES

SHARE CLASS CODE	FULL TITLE
A (or any letter of alphabet)	CLASS A SHARES (The letter will change depending on the class code eg B, C, D)
EMP	EMPLOYEES SHARES
FOU	FOUNDERS SHARES
LG	LIFE GOVERNORS SHARES
MAN	MANAGEMENT SHARES
ORD	ORDINARY SHARES
RED	REDEEMABLE SHARES
SPE	SPECIAL SHARES
PRF	PREFERENCE SHARES
CUMP	CUMULATIVE PREFERENCE SHARES
NCP	NON-CUMULATIVE PREFERENCE SHARES
REDP	REDEEMABLE PREFERENCE SHARES
NRP	NON-REDEEMABLE PREFERENCE SHARES
CRP	CUMULATIVE REDEEMABLE PREFERENCE SHARES
NCRP	NON-CUMULATIVE REDEEMABLE PREFERENCE SHARES
PARP	PARTICIPATIVE PREFERENCE SHARES

NAME AVAILABILITY OBJECTION CODES

OBJECTION CODE	OBJECTION DESCRIPTION
ABORCORP	Objectionable without consent of minister
AVBLRSV	Identical to a defunct reserved name
BUSSNAME	Name is identical to a registered business name
CAVTNAME	Name is identical to existing name caveat
CAVTWORD	Name contains existing word caveat
CNCLRSV	Identical to a cancelled reserved name
COMONWTH	Unacceptable unless used geographically
CONCROWN	Objectionable unless connection to crown exists
CONDEPMT	Objectionable unless connection with depts exis
CONDOMIN	Objectionable unless connection exists
CONFEDRL	Name suggests connection with federal government
CONFORGN	Suggests connection with foreign government
CONGOVT	Suggests connection with state or federal govt
CONMUNIC	Suggests connection with municipal council etc.
CONROYAL	suggests connection with member of royal family
CONSERVS	Suggests connection with exservicemens organsn
CONSTATE	Suggests connection with state/territory govt
EXISTAPL	Identical to a current reserved business name
EXISTCOY	Identical to an already registered corporation
EXISTLCA	Identical to a s150 or consent application
EXISTRSV	Identical to a current reserved name
INVCHARS	Name contains invalid characters
MEMBHCAP	Name suggests members are incapacitated
OBJANZAC	Object without consent of min for veteran affairs
OBJBRADM	Suggests a connection with Sir Donald Bradman
OBJCHAMB	Objectionable without consent of minister
OBJEXSV	Obj phrase - rsl, returned services league
OBJPOLII	Suggests a connection with the police

OBJSIMLR	Similar to existing.may require further info s1274
OBJS1115	Name contains proscribed phrase under s1115 cl
OBJTBANK	Name restricted without consent of APRA
OBJTCOOP	Restricted unless corp is a cooperative society
OBJTDEFN	Object without consent of minister for defence
OBJTUNAT	Object without consent of min for foreign affairs
OBJTUNIV	Object without consent of minister for education
OFFENSIV	Offensive to public or Complex content of public
PATROYAL	Suggests royal patronage has been given
UNACCEPT	Name is considered unacceptable